



Product Specification

G101STN01.C

AU OPTRONICS CORPORATION

() Preliminary Specifications

(V) Final Specifications

Module	10.1 Inch Color TFT-LCD
Model Name	G101STN01.C

Customer	Date
_____	_____
Checked & Approved by	
_____	_____

Approved by	Date
Grace Hung	2019/03/20
Prepared by	
Kevin Tseng	2019/03/20

Note: This Specification is subject to change without notice.

General Display Business Division /
AU Optronics corporation



Contents

- 1. Operating Precautions.....4**
- 2. General Description.....5**
 - 2.1 Display Characteristics.....5
 - 2.2 Optical Characteristics..... 6
- 3. Functional Block Diagram..... 9**
- 4. Absolute Maximum Ratings..... 10**
 - 4.1 Absolute Ratings of TFT LCD Module..... 10
 - 4.2 Absolute Ratings of Environment..... 10
- 5. Electrical Characteristics.....11**
 - 5.1 TFT LCD Module..... 11
 - 5.2 Backlight Unit..... 14
- 6. Signal Characteristic.....15**
 - 6.1 Pixel Format Image..... 15
 - 6.2 Scanning Direction..... 15
 - 6.3 Signal Description..... 16
 - 6.4 The Input Data Format..... 18
 - 6.5 Interface Timing..... 19
 - 6.6 Power ON/OFF Sequence..... 20
- 7. Connector & Pin Assignment..... 21**
 - 7.1 TFT LCD Module: LVDS Connector..... 21
- 8. Reliability Test Criteria..... 22**
- 9. Mechanical Characteristics.....23**
 - 9.1 LCM Outline Dimension (Front View)..... 23
 - 9.2 LCM Outline Dimension (Rear View)..... 24
- 10. Label and Packaging.....25**
 - 10.1 Shipping Label (on the rear side of TFT-LCD display)..... 25
 - 10.2 Carton Package..... 25
- 11. Safety.....26**
 - 11.1 Sharp Edge Requirements..... 26
 - 11.2 Materials..... 26
 - 11.3 Capacitors..... 26
 - 11.4 National Test Lab Requirement..... 26
- 12. Appendix..... 27**



1. Operating Precautions

- 1) Since front polarizer is easily damaged, please be cautious and not to scratch it.
- 2) Be sure to turn off power supply when inserting or disconnecting from input connector.
- 3) Wipe off water drop immediately. Long contact with water may cause discoloration or spots.
- 4) When the panel surface is soiled, wipe it with absorbent cotton or soft cloth.
- 5) Since the panel is made of glass, it may be broken or cracked if dropped or bumped on hard surface.
- 6) To avoid ESD (Electro Static Discharge) damage, be sure to ground yourself before handling TFT-LCD Module.
- 7) Do not open nor modify the module assembly.
- 8) Do not press the reflector sheet at the back of the module to any direction.
- 9) In case if a module has to be put back into the packing container slot after it was taken out from the container, do not press the center of the LED light bar edge. Instead, press at the far ends of the LED light bar edge softly. Otherwise the TFT Module may be damaged.
- 10) At the insertion or removal of the Signal Interface Connector, be sure not to rotate nor tilt the Interface Connector of the TFT Module.
- 11) TFT-LCD Module is not allowed to be twisted & bent even force is added on module in a very short time. Please design your display product well to avoid external force applying to module by end-user directly.
- 12) Small amount of materials having no flammability grade is used in the LCD module. The LCD module should be supplied by power complied with requirements of Limited Power Source (IEC60950 or UL1950), or be applied exemption.
- 13) Severe temperature condition may result in different luminance, response time and lamp ignition voltage.
- 14) Continuous operating TFT-LCD display under low temperature environment may accelerate lamp exhaustion and reduce luminance dramatically.
- 15) The data on this specification sheet is applicable when LCD module is placed in landscape position.
- 16) Continuous displaying fixed pattern may induce image sticking. It's recommended to use screen saver or shuffle content periodically if fixed pattern is displayed on the screen.



2. General Description

This specification applies to the Color Active Matrix Liquid Crystal Display G101STN01.C composed of a TFT-LCD display, a driver and power supply circuit, and a LED backlight system. The screen format is intended to support Wide SVGA (1024(H) x 600(V)) screen and 262k/16.7M colors (LVDS 6/8-bits). And LED driving circuit for backlight unit is included in G101STN01.C.

All input signals are LVDS interface.

G101STN01.C designed with wide viewing angle; wide temperature and long life LED backlight (50K hrs) is well suited for industrial applications.

G101STN01.C is a RoHS product.

2.1 Display Characteristics

The following items are characteristics summary on the table under 25 °C condition:

Items	Unit	Specifications
Screen Diagonal	[inch]	10.1
Active Area	[mm]	222.72(H) x 125.28(V)
Pixels H x V		1024 (RGB)x 600
Pixel Pitch	[mm]	0.2175(H)x0.2088(V)
Pixel Arrangement		R. G. B. Stripe
Display Mode		TN, Normally White
Nominal Input Voltage VCCS	[Volt]	3.3 (typ.)
Typical Power Consumption	[Watt]	3.3 (BLU)+0.53(Logic) = 3.83 W (Max.)
Weight	[Grams]	180(typ.)
Physical Size	[mm]	235(H)x143(V)x4.9(T) (typ.)
Electrical Interface		LVDS
Surface Treatment		AG, (3H)
Color Gamut	%	45
Support Color		262K/16.7M colors
Temperature Range Operating Storage (Non-Operating)	[°C] [°C]	-30 to +80 -30 to +80
RoHS Compliance		RoHS Compliance
Gray scale inversion direction		6 o'clock (gray inversion) [PCBA side]

2.2 Optical Characteristics

The optical characteristics are measured under stable conditions at 25 °C (Room Temperature):

Item	Unit	Conditions	Min.	Typ.	Max.	Note
White Luminance	[cd/m ²]	ILED= 41 mA (center point)	400	500	-	1
Uniformity	%	5 points	80	-	-	2,3
Contrast Ratio			400	500	-	4
Response Time	[msec]	Rising + Falling	-	20	35	5
Viewing Angle	[degree]	Horizontal (Right) CR = 10 (Left)	60	70	-	6
	[degree]		60	70		
	[degree]	Vertical (Upper) CR = 10 (Lower)	50	60	-	
Color / Chromaticity Coordinates (CIE 1931)	-	Red x	0.512	0.562	0.612	-
		Red y	0.281	0.331	0.381	
		Green x	0.279	0.329	0.379	
		Green y	0.522	0.572	0.622	
		Blue x	0.11	0.160	0.210	
		Blue y	0.084	0.134	0.184	
		White x	0.263	0.313	0.363	
		White y	0.279	0.329	0.379	

Note 1: Measurement method

Equipment Pattern Generator, Power Supply, Digital Voltmeter, Luminance meter (SR_3 or equivalent)

Aperture 1 ϕ with 50cm viewing distance

Test Point Center

Environment < 1 lux

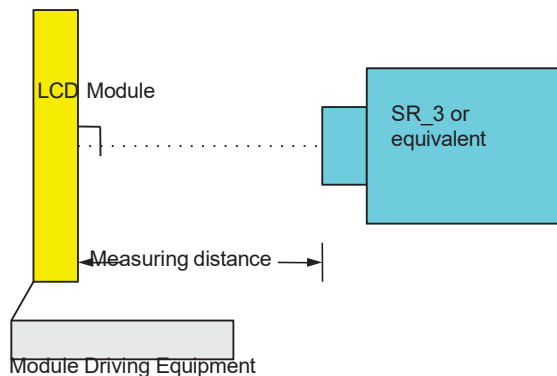

Note 2: Definition of 5 points position (Display active area: 222.72(H) x 125.28(V))
 Measure the luminance of gray level 63 at 5 points

$$\delta W_{5p} = \{ \text{Minimum} [L(1) \sim L(5)] / \text{Maximum} [L(1) \sim L(5)] \} * 100\%$$

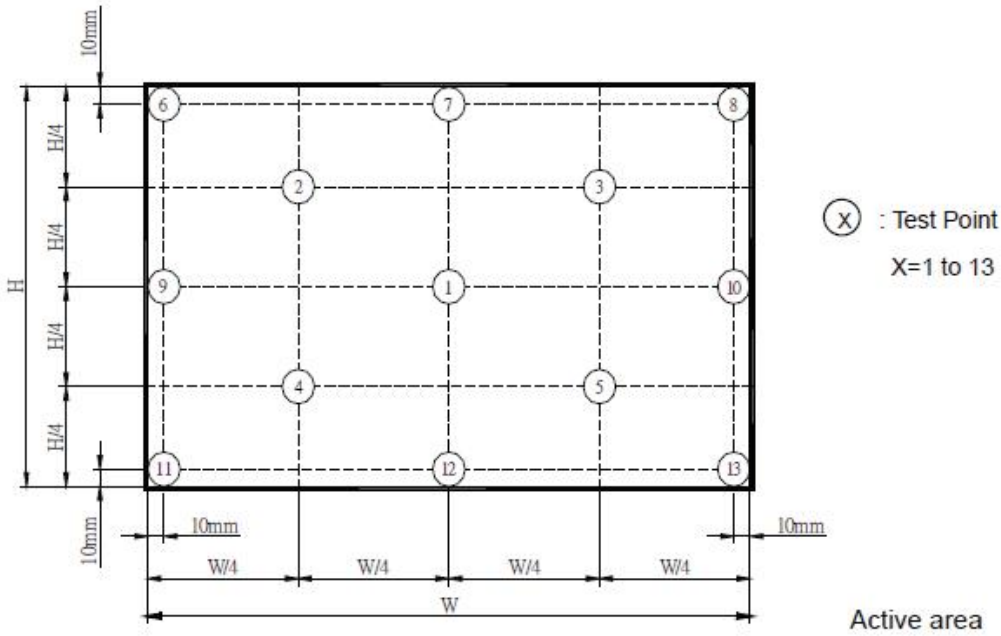

Note 3: The luminance uniformity of 5 points is defined by dividing the minimum luminance values by the maximum test point luminance

$$\delta_{W5} = \frac{\text{Minimum Brightness of five points}}{\text{Maximum Brightness of five points}}$$

Note 4: Definition of contrast ratio (CR):

$$\text{Contrast ratio (CR)} = \frac{\text{Brightness on the "White" state}}{\text{Brightness on the "Black" state}}$$

Note 5: Definition of response time:

The output signals of photo detector are measured when the input signals are changed from "White" to "Black" (falling time) and from "Black" to "White" (rising time), respectively. The response time interval is between 10% and 90% of amplitudes. Please refer to the figure as below.

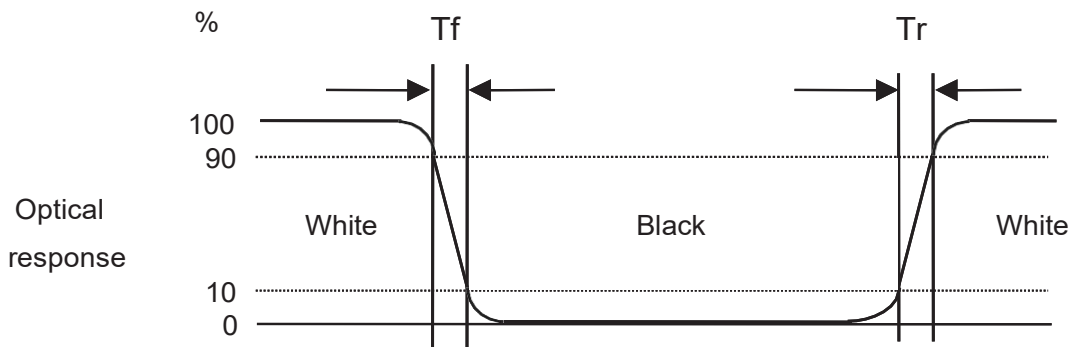

Note 6: Definition of viewing angle

Viewing angle is the measurement of contrast ratio ≥ 10 , at the screen center, over a 180° horizontal and 180° vertical range (off-normal viewing angles). The 180° viewing angle range is broken down as below: 90° (θ) horizontal left and right, and 90° (Φ) vertical high (up) and low (down). The measurement direction is typically perpendicular to the display surface with the screen rotated to its center to develop the desired measurement viewing angle.

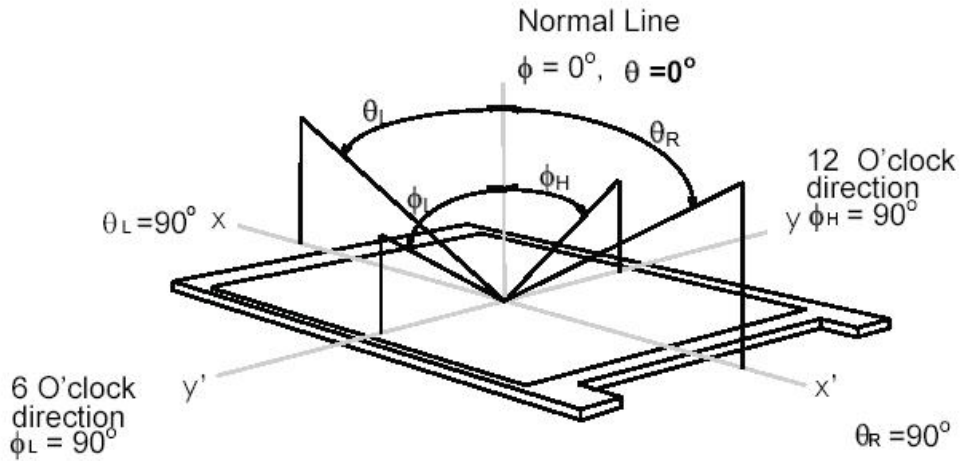

3. Functional Block Diagram

The following diagram shows the functional block of the 10.1 inch color TFT/LCD module:

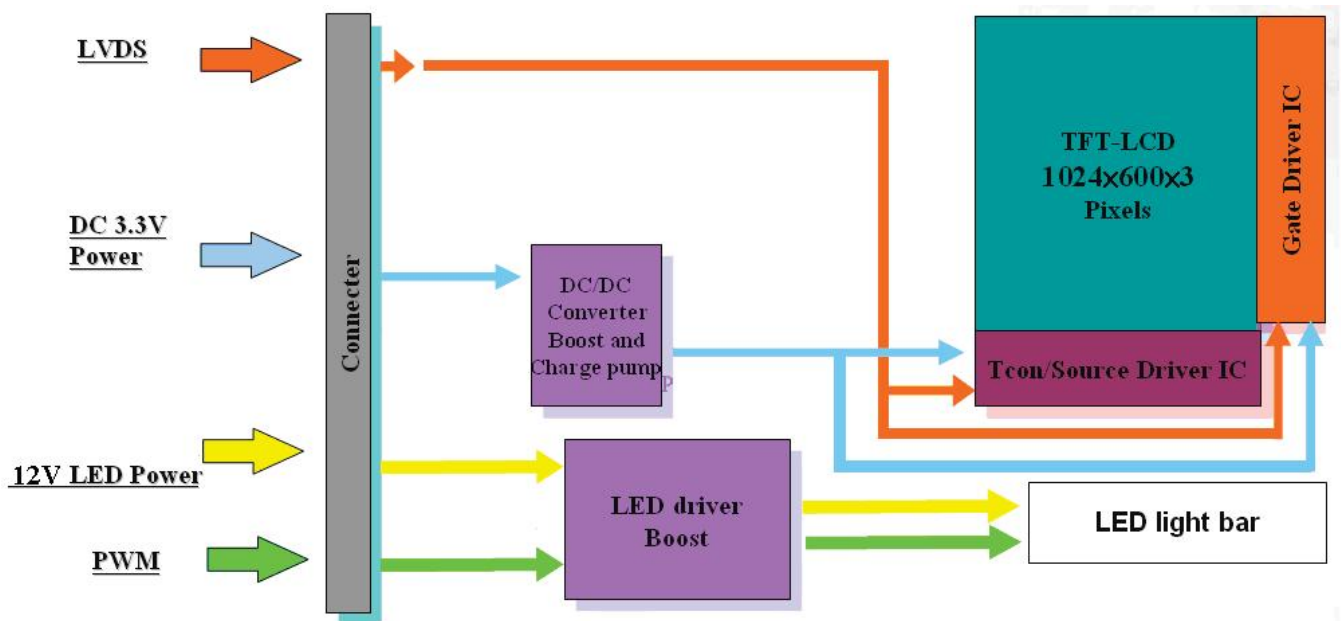

4. Absolute Maximum Ratings

4.1 Absolute Ratings of TFT LCD Module

Item	Symbol	Min	Max	Unit
Logic/LCD drive Voltage	VCCS	-0.3	4	[Volt]
EDID drive Voltage	VEDID	-0.3	4	[Volt]
Converter Input Voltage	LED_VCCS	-0.3	23	[Volt]
Converter Control Signal Voltage	LED_PWM	-0.3	6	[Volt]
Converter Control Signal Voltage	LED_EN	-0.3	6	[Volt]

4.2 Absolute Ratings of Environment

Item	Symbol	Min	Max	Unit
Operating Temperature	TOP	-30	80	[°C]
Storage Temperature	TST	-30	80	[°C]

Note: Maximum Wet-Bulb should be 39 °C and no condensation.

5. Electrical Characteristics

5.1 TFT LCD Module

5.1.1 Power Specification

Input power specifications are shown as follows;

Symbol	Parameter	Min	Typ	Max	Units	Remark
VCCS	Logic/LCD Drive Voltage	3	3.3	3.6	[Volt]	
I _{VCCS}	VCCS Current	-	140	160	[mA]	Black Pattern (VCCS=3.3V, at 60Hz)
I _{rush}	LCD Inrush Current	-	-	1.5	[A]	Note 1
P _{VCCS}	VCCS Power	-	0.46	0.53	[Watt]	Black Pattern (VCCS=3.3V, at 60Hz)
VCCS _{rp}	Allowable Logic/LCD Drive Ripple Voltage			150	[mV] p-p	

Note 1: Measurement condition:

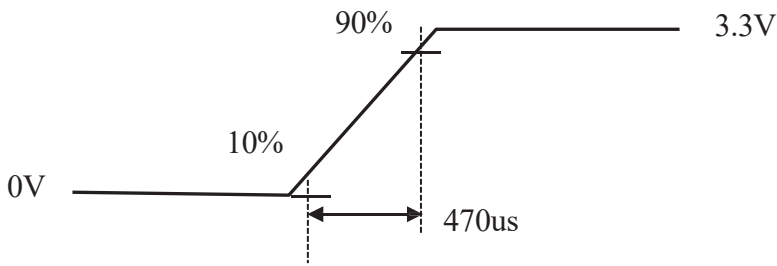

VCCS rising time



Black pattern

5.1.2 LVDS DC Electrical Characteristics

Input signals shall be low or Hi-Z state when VCCS is off.

Symbol	Item	Min.	Typ.	Max.	Unit	Remark
VTH	Differential Input High Threshold	-	-	100	[mV]	
VTL	Differential Input Low Threshold	-100	-	-	[mV]	
VID	Input Differential Voltage	100	-	600	[mV]	
VICM	Differential Input Common Mode Voltage	1.125	-	1.375	[V]	
ICRTC	LVDS Terminating Resistor	-	100	-	Ω	LVDS terminating resistor is embedded in LCD

Note: LVDS Signal Waveform.

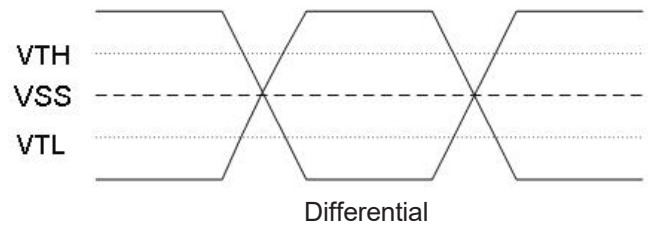
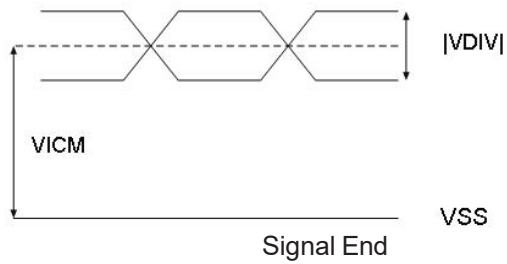

5.1.3 LVDS AC Electrical Characteristics

Symbol	Item	Min.	Typ.	Max.	Unit	Remark
tSKD	Differential Pulse Skew 差 $t_{PHLD} - t_{PLHD}$ 差			0.5	[ns]	
tTLH	Transition Low to High Time			1	[ns]	
tTHL	Transition High to Low Time			1	[ns]	
VOS	Offset Voltage imbalance			200	[mV]	

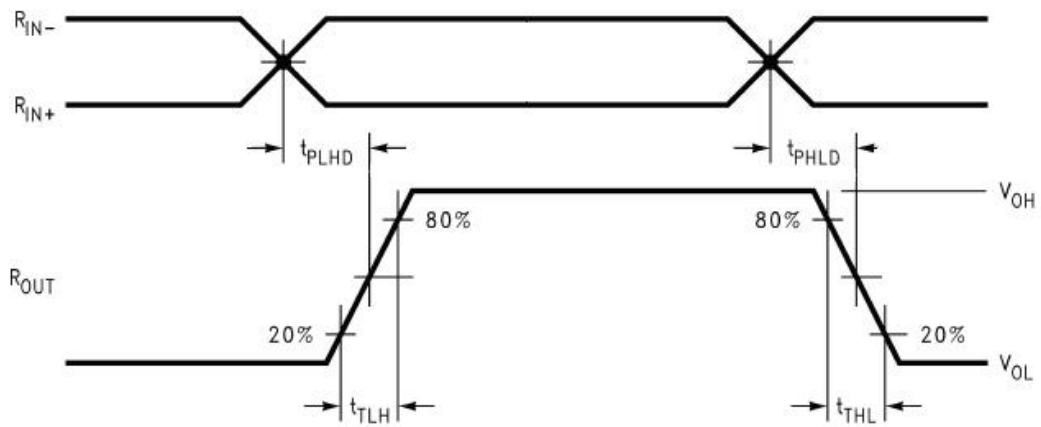

5.2 Backlight Unit

5.2.1 Parameter guideline for LED

Following characteristics are measured under a stable condition using an inverter at 25H (Room Temperature):

Symbol	Parameter		Min.	Typ.	Max.	Unit	Remark
LED_VCCS	Input Voltage		9	12	15	[Volt]	
I _{LED} RUSH	Inrush Current		-	-	1.5	[A]	
I _{LED}	Input Current		-	225	270	[mA]	Note 2
P _{LED}	Power Consumption		-	2.7	3.3	[Watt]	Note 2
LED_EN	EN Control	BL On	2.3	-	5	[Volt]	
	Level	BL Off	0	-	0.5		
F _{PWM}	PWM Control Frequency		190	-	2000	[Hz]	PWM Control
D _{PWM}	PWM Control Duty Ratio		10	-	100	[%]	
V _{PWM}	PWM Control Level	High Level	2.3	-	5	[Volt]	
		Low Level	0	-	0.5		

LED Features:

I _F	LED Forward Current	-	41	-	[mA]	Ta = 25°C
V _F	LED Forward Voltage	-	31	34	[Volt]	I _F = 41 mA, Ta = 25°C
P _{LED}	LED Power Consumption	-	2.54	2.79	[Watt]	I _F = 41 mA, Ta = 25°C LED per string Power
Operation Life		50,000	-	-	Hrs	I _F = 41 mA, Ta = 25°C

Note 1: Ta means ambient temperature of TFT-LCD module.

Note 2: I_{LED}RUSH, I_{LED}, P_{LED} are defined for LED backlight and tested when LED_VCCS = 12V and 100% duty of PWM dimming.

Note 3: I_F, V_F are defined for one channel LED. There are two LED channel in back light unit.

Note 4: If G101STN01.C module is driven by high current or at high ambient temperature & humidity condition. The operating life will be reduced.

Note 5: Operating life means brightness goes down to 50% initial brightness. Minimum operating life time is estimated data.

6. Signal Characteristic

6.1 Pixel Format Image

Following figure shows the relationship between input signal and LCD pixel format.

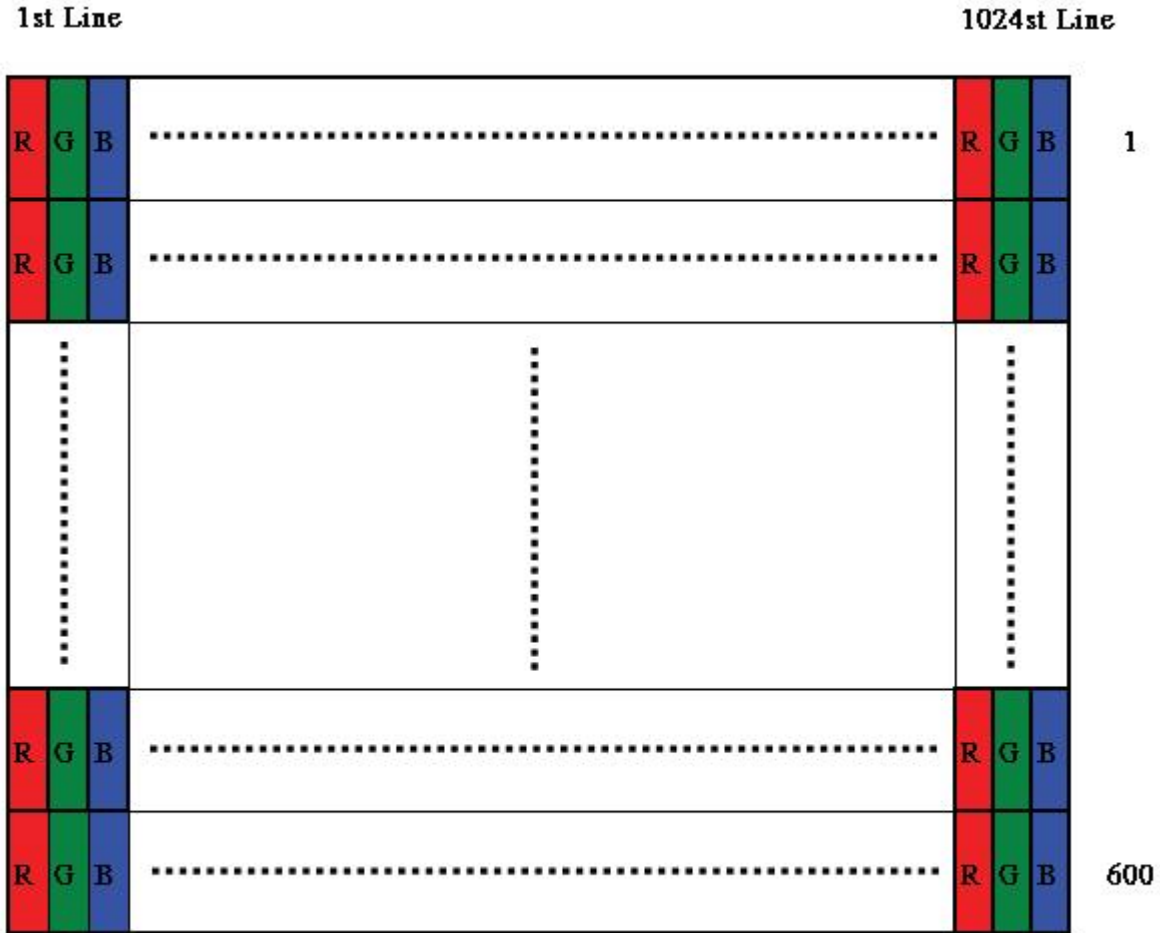

6.2 Scanning Direction

The following figures show the image seen from the front view. The arrow indicates the direction of scan.



6.3 Signal Description

The module uses a LVDS receiver embedded in AUO's ASIC. LVDS is a differential signal technology for LCD interface and a high-speed data transfer device.

Pin no	Symbol	Function	Remark
1	NC	No Connection (Reserve)	1k pull-down resistance in LCM
2	VCCS	Power Supply (3.3V typ.)	
3	VCCS	Power Supply (3.3V typ.)	
4	VEDID	DDC 3.3V power	If EDID function is not used, please keep it floating..
5	NC	No Connection (Reserved for AUO test)	100k pull-down resistance in LCM
6	CLKEDID	DDC clock	If EDID function is not used, please keep it floating.
7	DATAEDID	DDC data	
8	Rxin0-	LVDS differential data input	
9	Rxin0+		
10	VSS	Ground	
11	Rxin1-	LVDS differential data input	
12	Rxin1+		
13	VSS	Ground	
14	Rxin2-	LVDS Differential Data Input	
15	Rxin2+		
16	VSS	Ground	
17	RxCLK-	LVDS differential clock input	
18	RxCLK+		
19	VSS	Ground	
20	Rxin3-	LVDS receiver signal channel 3 pin20 & pin21 connect to GND or NC for 6bit LVDS Input	
21	Rxin3+		
22	VSS	Ground	
23	NC	No Connection (Reserved for AUO test)	
24	NC	No Connection (Reserved for AUO test)	
25	VSS	Ground	
26	Order_SEL	LVDS format selection. Order_SEL = "H" : JEIDA / Order_SEL = "L" or NC : NS-Like	



Product Specification

G101STN01.C

AU OPTRONICS CORPORATION

27	SEL68	6/8bits LVDS data input selection SEL68 =“H”: 8bits / SEL68 =“L” or NC: 6bit	
28	VSS	Ground	



Pin no	Symbol	Function	Remark
29	NC	No Connection (Reserve)	
30	NC	No Connection (Reserve)	
31	LED_GND	LED Ground	
32	LED_GND	LED Ground	
33	LED_GND	LED Ground	
34	NC	No Connection (Reserve)	
35	LED_PWM	PWM Control Signal of LED Converter	
36	LED_EN	Enable Control Signal of LED Converter	
37	NC	No Connection (Reserve)	
38	LED_VCCS	LED Power Supply (12V typ.)	
39	LED_VCCS	LED Power Supply (12V typ.)	
40	LED_VCCS	LED Power Supply (12V typ.)	

Note 1: Input Signals shall be in low status when VCCS is off.

Note 2: NC means "No Connection".

6.4 The Input Data Format

6.4.1 SEL68 and Order_SEL

SEL68 = "Low" or "NC" for 6 bits LVDS Input

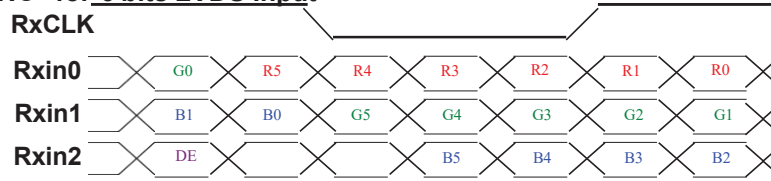

SEL68 = "High" and Order_SEL = "Low" or "NC" for 8 bits NS-Like Input

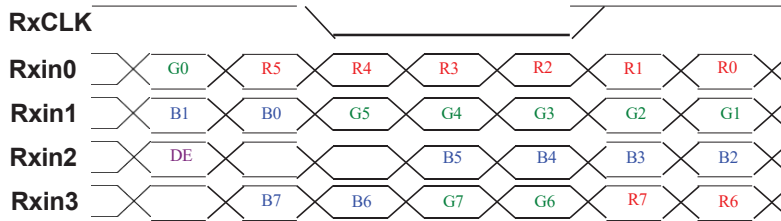

SEL68 = "High" and Order_SEL = "H" for 8 bits JEIDA Input

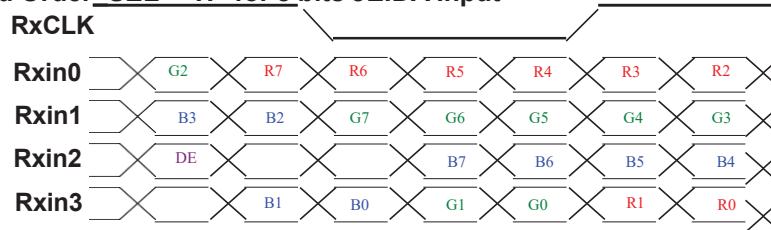

Signal Name	Description	Remark
R7	Red Data 7	Red-pixel Data For 8Bits LVDS input MSB: R7 ; LSB: R0
R6	Red Data 6	
R5	Red Data 5	
R4	Red Data 4	
R3	Red Data 3	
R2	Red Data 2	
R1	Red Data 1	
R0	Red Data 0	Green-pixel Data For 8Bits LVDS input MSB: G7 ; LSB: G0
G7	Green Data 7	
G6	Green Data 6	
G5	Green Data 5	
G4	Green Data 4	
G3	Green Data 3	
G2	Green Data 2	
G1	Green Data 1	
G0	Green Data 0	Blue-pixel Data For 8Bits LVDS input MSB: B7 ; LSB: B0
B7	Blue Data 7	
B6	Blue Data 6	
B5	Blue Data 5	
B4	Blue Data 4	
B3	Blue Data 3	
B2	Blue Data 2	
B1	Blue Data 1	
B0	Blue Data 0	When the signal is high, the pixel data shall be valid to be displayed.
RxCLKIN	LVDS Data Clock	
DE	Data Enable Signal	

Note1: Please follow PSWG.

Note2: Output signals from any system shall be low or Hi-Z state when VCCS is off.

6.5 Interface Timing

6.5.1 Timing Characteristics

Signal	Symbol	Min.	Typ.	Max.	Unit	
Clock Frequency	T _{dclk}	40.8	51.2	67.2	MHz	
Vertical Section	Period	T _V	610	635	800	T _{Line}
	Active	T _{VD}	600	600	600	
	Blanking	T _{VB}	10	35	200	
Horizontal Section	Period	T _H	1114	1344	1400	T _{dclk}
	Active	T _{HD}	1024	1024	1024	
	Blanking	T _{HB}	90	320	376	
Frame Rate	F	50	60	70	Hz	

Note : DE mode.

6.5.2 Input Timing Diagram

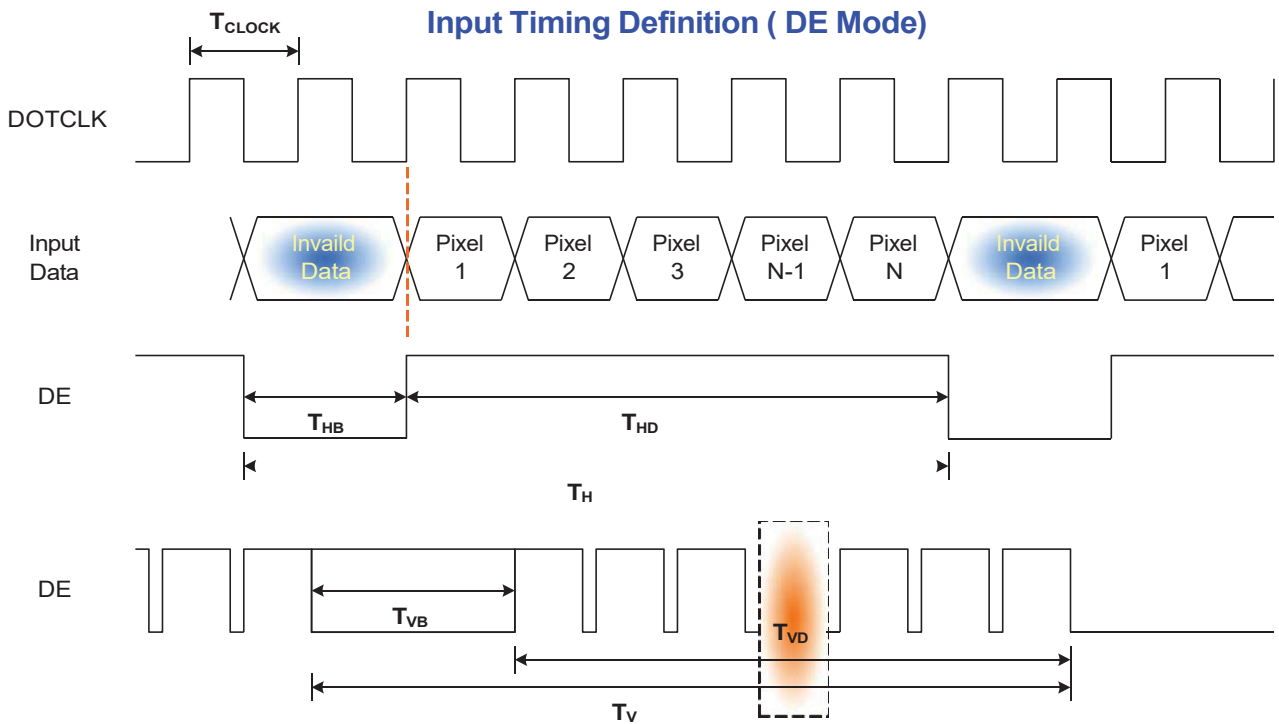

6.6 Power ON/OFF Sequence

VCCS power and lamp on/off sequence is as below. Interface signals are also shown in the chart. Signals from any system shall be Hi-Z state or low level when VCCS is off.

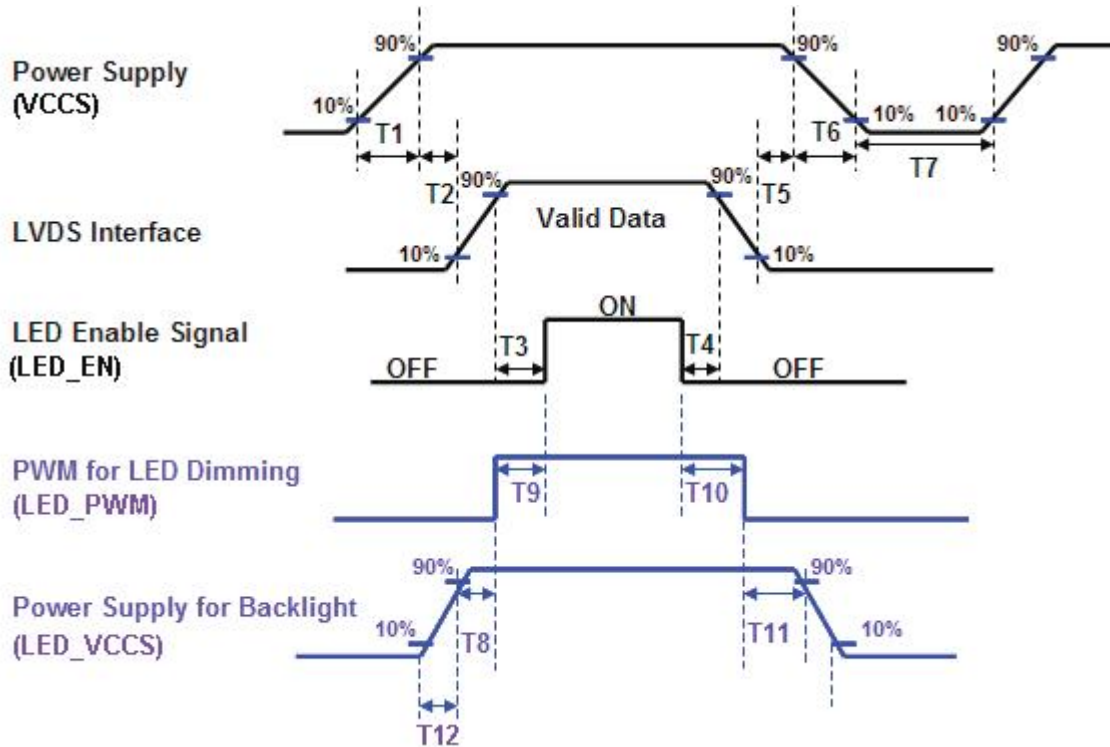

Power ON/OFF sequence timing

Parameter	Value			Units
	Min.	Typ.	Max.	
T1	0.5	-	10	[ms]
T2	0	-	50	[ms]
T3	200	-	-	[ms]
T4	200	-	-	[ms]
T5	0	-	50	[ms]
T6	0	-	10	[ms]
T7	500	-	-	[ms]
T8	10	-	-	[ms]
T9	10	-	-	[ms]
T10	10	-	-	[ms]
T11	10	-	-	[ms]
T12	0.5	-	10	[ms]

The above on/off sequence should be applied to avoid abnormal function in the display. Please make sure to turn off the power when you plug the cable into the input connector or pull the cable out of the connector.

7. Connector & Pin Assignment

Physical interface is described as for the connector on module. These connectors are capable of accommodating the following signals and will be following components.

7.1 TFT LCD Module: LVDS Connector

Connector Name / Designation	Signal Connector
Manufacturer	IPEX or compatible
Connector Model Number	IPEX 20455-040E-12R or compatible
Adaptable Plug	IPEX 20453-040T-01 or compatible

Pin No.	Symbol	Pin No.	Symbol
1	NC	21	Rxin3+
2	VCCS	22	VSS
3	VCCS	23	NC
4	VEDID	24	NC
5	NC	25	VSS
6	CLKEDID	26	Order_SEL
7	DATAEDID	27	SEL68
8	Rxin0-	28	VSS
9	Rxin0+	29	NC
10	VSS	30	NC
11	Rxin1-	31	LED_GND
12	Rxin1+	32	LED_GND
13	VSS	33	LED_GND
14	Rxin2-	34	NC
15	Rxin2+	35	LED_PWM
16	VSS	36	LED_EN
17	RxCLK-	37	NC
18	RxCLK+	38	LED_VCCS
19	VSS	39	LED_VCCS
20	Rxin3-	40	LED_VCCS

8. Reliability Test Criteria

Items	Required Condition	Note
Temperature Humidity Bias	40 °C /90%,300Hr	
High Temperature Operation	80 °C, 300Hr	
Low Temperature Operation	-30 °C, 300Hr	
Hot Storage	80 °C, 300 hours	
Cold Storage	-30 °C, 300 hours	
Thermal Shock Test	-30 °C /30 min ,80 °C /30 min ,100cycles	
Shock Test (Non-Operating)	50G,20ms,Half-sine wave,(+X,+Y,+Z)	
Vibration Test (Non-Operating)	1.5G, 10~200~10Hz, Sine wave 30mins/axis, 3 direction (X, Y, Z)	
ESD	Contact Discharge = ± 8 kV, class B (R=330,C=150pF) Air Discharge = ± 15 kV, class B (R=330,C=150pF) 1sec, 9 points, 25 times/point	Note1

Note 1: According to EN61000-4-2 , ESD Class B: Some performance degradation allowed. No data lost . Self-recoverable. No hardware failures.

Note 2: After reliability test, it is no function defect and occurrence of any new defective shall not be allowed.

Note 3:

- Water condensation is not allowed for each test items.
- Each test is done by new TFT-LCD module. Don't use the same TFT-LCD module repeatedly for reliability test.
- The reliability test is performed only to examine the TFT-LCD module capability.
- To inspect TFT-LCD module after reliability test, please store it at room temperature and room humidity for 24 hours at least in advance.



Product Specification

AU OPTRONICS CORPORATION

G101STN01.C

9. Mechanical Characteristics

9.1 LCM Outline Dimension (Front View)

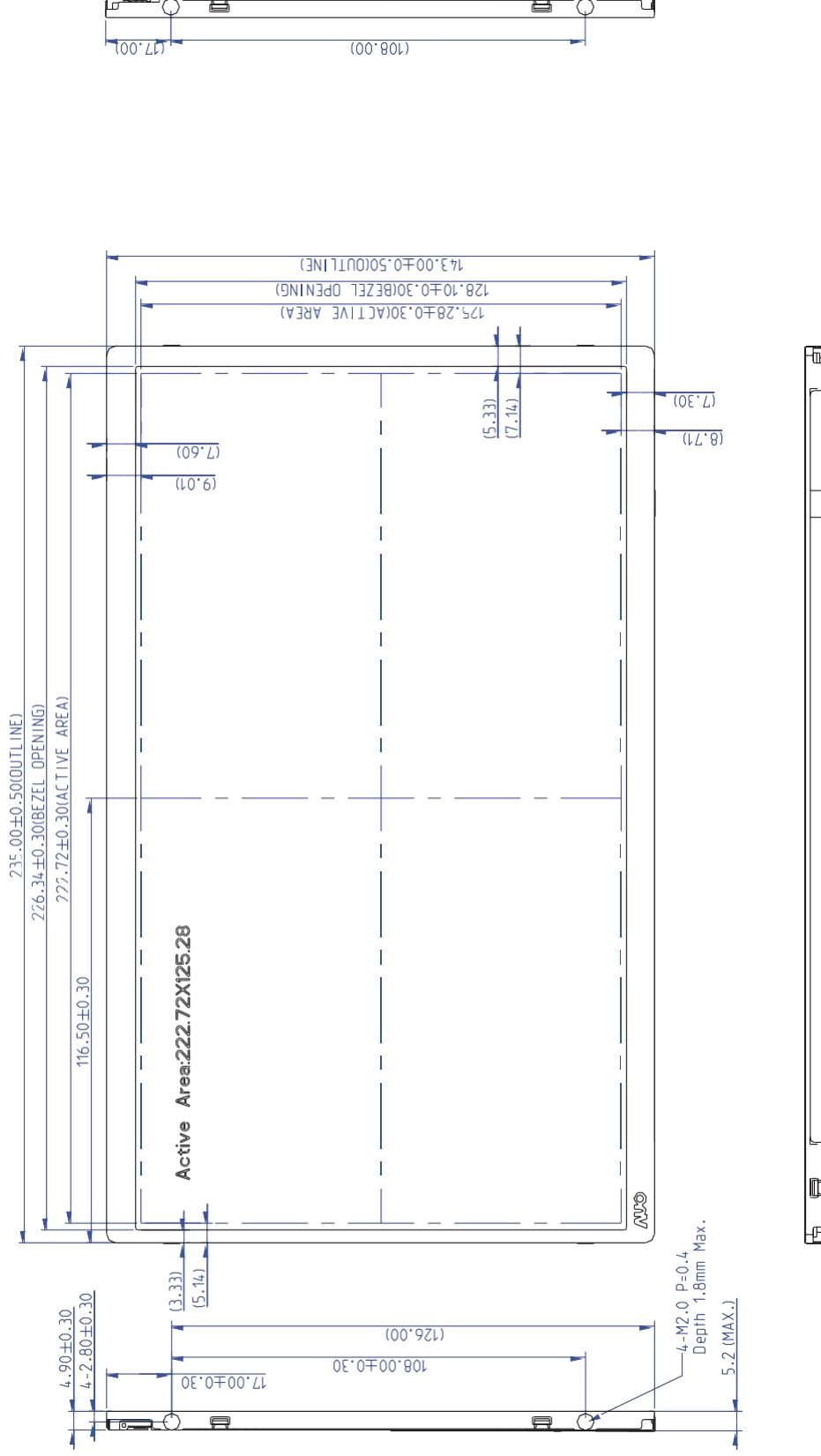



Product Specification

AU OPTRONICS CORPORATION

G101STN01.C

9.2 LCM Outline Dimension (Rear View)

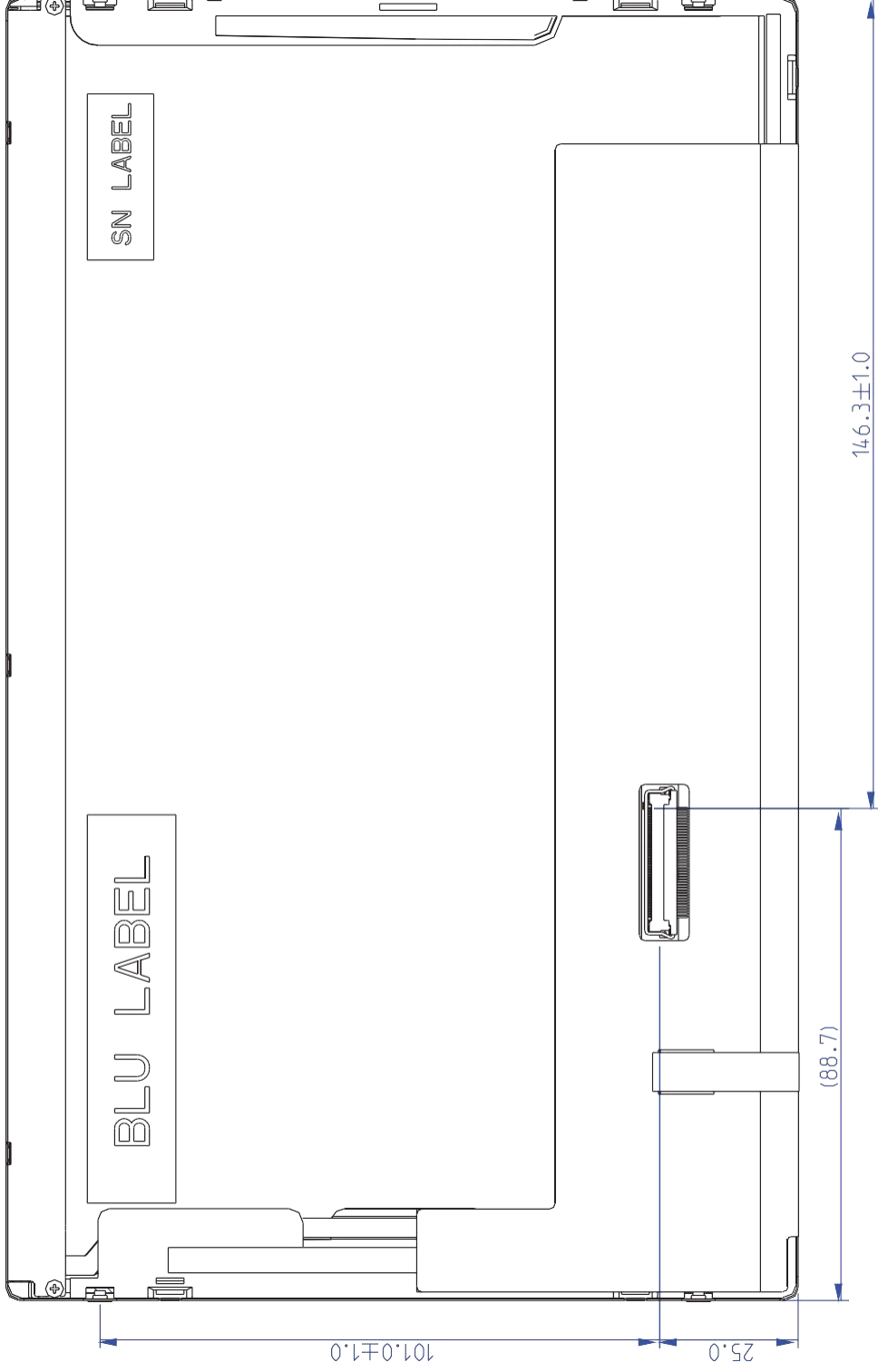

10. Label and Packaging

10.1 Shipping Label (on the rear side of TFT-LCD display)

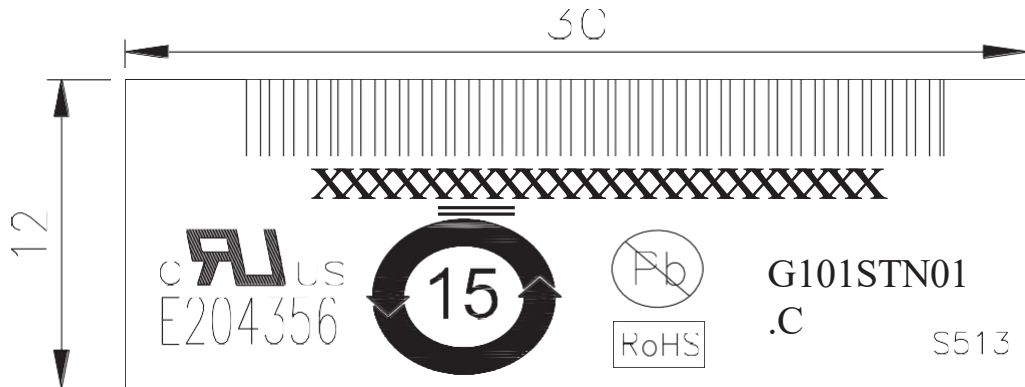

10.2 Carton Package

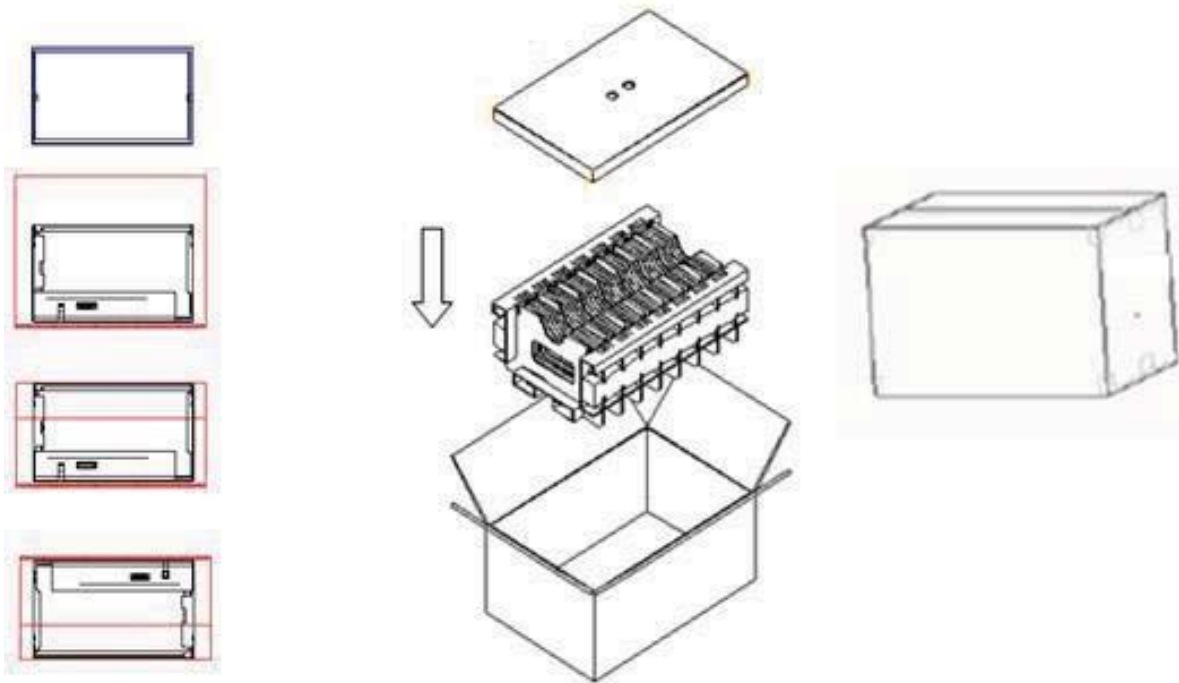

Max capacity.35pcs TFT-LCD module per carton

Max weight: 9.9 kg per carton

Outside dimension of carton: 528*348*252mm

Pallet size.1,070mm*1,070mm*135mm

Box stacked

ASRS_LAYERS.5 layers

Module by air.(2 *3) *5 layers'one pallet put 30 boxes'total 1,050 pcs module

Module by sea.(2 *3) *5 layers + (2 *3) *2 layers , two pallet put 42 boxes'total 1,470 pcs module

Module by sea_HQ.(2 *3) *5 layers+(2 *3) *3 layers, two pallet put 48 boxes, total 1,680 pcs module



11. Safety

11.1 Sharp Edge Requirements

There will be no sharp edges or comers on the display assembly that could cause injury.

11.2 Materials

11.2.1 Toxicity

There will be no carcinogenic materials used anywhere in the display module. If toxic materials are used, they will be reviewed and approved by the responsible AUO toxicologist.

11.2.2 Flammability

All components including electrical components that do not meet the flammability grade UL94-V1 in the module will complete the flammability rating exception approval process.

The printed circuit board will be made from material rated 94-V1 or better. The actual UL flammability rating will be printed on the printed circuit board.

11.3 Capacitors

If any polarized capacitors are used in the display assembly, provisions will be made to keep them from being inserted backwards.

11.4 National Test Lab Requirement

The display module will satisfy all requirements for compliance to:

UL 60950-1 second edition

U.S.A. Information Technology Equipment



12. Appendix

Address	FUNCTION	Value	Value	Value	Note
HEX		HEX	BIN	DEC	
00	Header	00	00000000	0	
01		FF	11111111	255	
02		FF	11111111	255	
03		FF	11111111	255	
04		FF	11111111	255	
05		FF	11111111	255	
06		FF	11111111	255	
07		00	00000000	0	
08	EISA Manuf. Code LSB	06	00000110	6	
09	Compressed ASCII	AF	10101111	175	
0A	Product Code	D2	11010010	210	
0B	hex, LSB first	10	00010000	16	
0C	32-bit ser #	00	00000000	0	
0D		00	00000000	0	
0E		00	00000000	0	
0F		00	00000000	0	
10	Week of manufacture	30	00110000	48	
11	Year of manufacture	17	00010111	23	
12	EDID Structure Ver.	01	00000001	1	
13	EDID revision #	00	00000000	0	
14	Video input def. (<i>digital I/P, non-TMDS, CRGB</i>)	80	10000000	128	
15	Max H image size (<i>rounded to cm</i>)	16	00010110	22	
16	Max V image size (<i>rounded to cm</i>)	0D	00001101	13	
17	Display Gamma (<i>=(gamma*100)-100</i>)	78	01111000	120	
18	Feature support (<i>no DPMS, Active OFF, RGB, tmg Blk#1</i>)	0A	00001010	10	
19	Red/green low bits (Lower 2:2:2:2 bits)	15	00010101	21	
1A	Blue/white low bits (Lower 2:2:2:2 bits)	85	10000101	133	
1B	Red x (Upper 8 bits)	97	10010111	151	
1C	Red y/ highER 8 bits	58	01011000	88	
1D	Green x	53	01010011	83	
1E	Green y	8A	10001010	138	
1F	Blue x	26	00100110	38	
20	Blue y	25	00100101	37	
21	White x	50	01010000	80	
22	White y	54	01010100	84	
23	Established timing 1	00	00000000	0	
24	Established timing 2	00	00000000	0	
25	Established timing 3	00	00000000	0	
26	Standard timing #1	01	00000001	1	
27		01	00000001	1	
28	Standard timing #2	01	00000001	1	
29		01	00000001	1	



Product Specification

G101STN01.C

AU OPTRONICS CORPORATION

2A	Standard timing #3	01	00000001	1
2B		01	00000001	1
2C	Standard timing #4	01	00000001	1
2D		01	00000001	1
2E	Standard timing #5	01	00000001	1
2F		01	00000001	1
30	Standard timing #6	01	00000001	1
31		01	00000001	1
32	Standard timing #7	01	00000001	1
33		01	00000001	1
34	Standard timing #8	01	00000001	1
35		01	00000001	1
36	Pixel Clock/10000 LSB	2D	00101101	45
37	Pixel Clock/10000 USB	11	00010001	17
38	Horz active Lower 8bits	00	00000000	0
39	Horz blanking Lower 8bits	A0	10100000	160
3A	HorzAct:HorzBlnk Upper 4:4 bits	40	01000000	64
3B	Vertical Active Lower 8bits	58	01011000	88
3C	Vertical Blanking Lower 8bits	13	00010011	19
3D	Vert Act : Vertical Blanking (upper 4:4 bit)	20	00100000	32
3E	HorzSync. Offset	32	00110010	50
3F	HorzSync.Width	20	00100000	32
40	VertSync.Offset : VertSync.Width	26	00100110	38
41	Horz&Vert Sync Offset/Width Upper 2bits	00	00000000	0
42	Horizontal Image Size Lower 8bits	DE	11011110	222
43	Vertical Image Size Lower 8bits	7D	01111101	125
44	Horizontal & Vertical Image Size (upper 4:4 bits)	00	00000000	0
45	Horizontal Border <i>(zero for internal LCD)</i>	00	00000000	0
46	Vertical Border <i>(zero for internal LCD)</i>	00	00000000	0
47	Signal <i>(non-intr, norm, no stero, sep sync, neg pol)</i>	18	00011000	24
48	Detailed timing/monitor	00	00000000	0
49	descriptor #2	00	00000000	0
4A		00	00000000	0
4B		0F	00001111	15
4C		00	00000000	0
4D		00	00000000	0
4E		00	00000000	0
4F		00	00000000	0
50		00	00000000	0
51		00	00000000	0
52		00	00000000	0
53		00	00000000	0
54		00	00000000	0
55		00	00000000	0
56		00	00000000	0



Product Specification

G101STN01.C

AU OPTRONICS CORPORATION

57		00	00000000	0	
58		00	00000000	0	
59		20	00100000	32	
5A	Detailed timing/monitor	00	00000000	0	
5B	descriptor #3	00	00000000	0	
5C		00	00000000	0	
5D		FE	11111110	254	
5E		00	00000000	0	
5F	Manufacture	41	01000001	65	A
60	Manufacture	55	01010101	85	U
61	Manufacture	4F	01001111	79	O
62		0A	00001010	10	
63		20	00100000	32	
64		20	00100000	32	
65		20	00100000	32	
66		20	00100000	32	
67		20	00100000	32	
68		20	00100000	32	
69		20	00100000	32	
6A		20	00100000	32	
6B		20	00100000	32	
6C	Detailed timing/monitor	00	00000000	0	
6D	descriptor #4	00	00000000	0	
6E		00	00000000	0	

6F		FE	11111110	254	
70		00	00000000	0	
71	Manufacture P/N	47	01000111	71	G
72	Manufacture P/N	31	00110001	49	1
73	Manufacture P/N	30	00110000	48	0
74	Manufacture P/N	31	00110001	49	1
75	Manufacture P/N	53	01010011	83	S
76	Manufacture P/N	54	01010100	84	T
77	Manufacture P/N	4E	01001110	78	N
78	Manufacture P/N	30	00110000	48	0
79	Manufacture P/N	31	00110001	49	1
7A	Manufacture P/N	2E	00101110	46	.
7B	Manufacture P/N	30	00110000	48	0
7C		0A	00001010	10	
7D		20	00100000	32	
7E	Extension Flag	00	00000000	0	
7F	Checksum	18	00011000	24	