



Specification For Approval

Preliminary specification

Final specification

Title	10.4SVGA(PS) TFT-LCD (Module)
--------------	--------------------------------------

Buyer	
Model	

Supplier	Cheng Du BOE Optoelectronics Technology CO./ LTD
Model	

TITLE/SIGNATURE	DATE
_____	_____
_____	_____
_____	_____
_____	_____

Please return one copy confirmation with signature and your comments

ITEM	SIGNATURE/DATE
Approved	_____
Reviewed	_____
Reviewed	_____
Prepared	_____

BOE CHENG DU
Optoelectronics Technology CO./ LTD



CONTENT LIST

Cover	1
Content List	2
Record of Revisions	3
1. General Description	4
2. Electrical Specifications	6
3. Signal Timing Specification	12
4. Interface Connection	15
5. Optical Specifications	17
6. Mechanical Characteristics	20
7. Reliability Test	23
8. Packing Method	24
9. Product ID Rule	25
10. Handling & Cautions	27
11. Applicable Scope	29



1.0 GENERAL DESCRIPTION

1.1 Introduction

10.4SVGA is a color active matrix TFT-LCD panel using amorphous silicon TFT's (Thin Film Transistors) as an active switching devices. This model is composed of a TFT-LCD Panel, a driving circuit and a back light system. It is a transmissive type display operating in the normal white. This TFT-LCD has a 10.4 inch diagonally measured active area with SVGA resolutions (800 horizontal by 600 vertical pixel array). Each pixel is divided into Red, Green, Blue dots which are arranged in vertical stripe and this panel can display 16.7M Dithering (RGB 8-Bits) or 262K colors (RGB 6-bits).

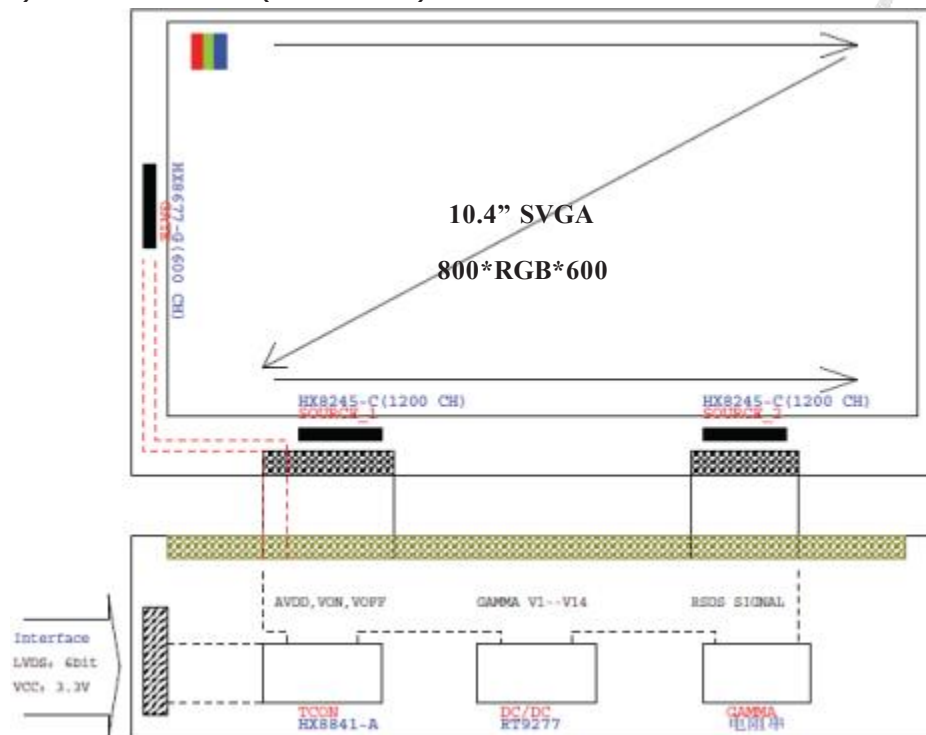

1.2 Features

- 0.5t Glass (Single)
- Module Design
- Low power consumption
- Thin and light weight
- High luminance and contrast ratio, low reflection and wide viewing angle
- RoHS Compliant

1.3 Application

- Medical & Industrial application

**1.4 General Specifications** (H: horizontal length, V: vertical length)

Parameter	Specification	Unit	Remark
Active Area	211.2(H) × 158.4(V)	mm	
Number of Pixels	800(H) RGB × 600(V)	pixels	
Pixel Pitch	0.264(H) × 0.264(V)	mm	
Pixel Arrangement	RGB Vertical stripe		
Display Colors	262K /16.7M Dithering color	colors	
Color Gamut	50%(typ.)		
Display Mode	Normally white, Transmissive mode		
Dimensional Outline	236(H) × 176.9(V) × 5.6(D)	mm	
Backlight	Top edge side, 1-LED Lighting Bar Type		
Polarizer surface treatment	Haze 25%(CF)/ Clear(TFT)		
Polarizer compensation type	Wide view		
Viewing Direction (Human Eye)	12 o'clock		Note 1,2
D-IC	HX8245(Source)+HX8677(Gate)		
Weight	288g (typ.)	gram	

Note:

- 1.The biggest CR Direction: 6 O'clock, The worst Gray Inversion direction: 6 O'clock.
- 2.The TFT and CF Rubbing Direction

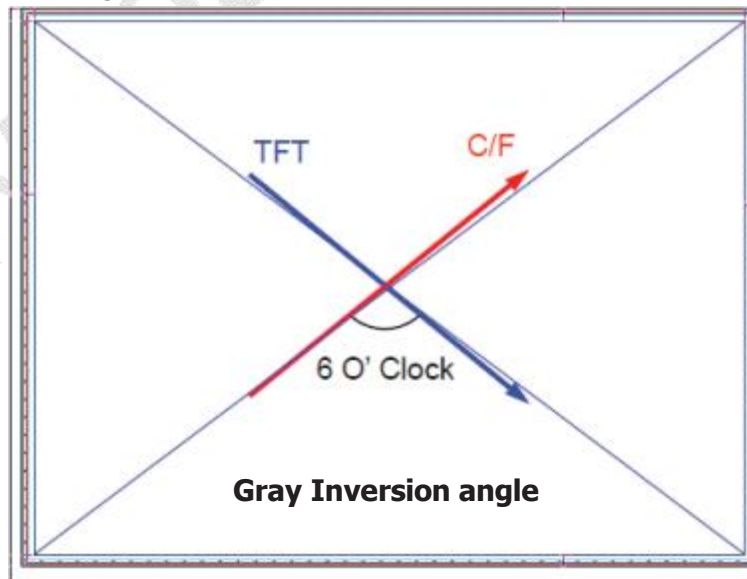

3. This product's compatible IC is HX8245 (Source) + HX8677 (Gate), Please contact IC manufacturer and verify it when you choose any one of them. The information we suppose about IC just for reference.



2.0 ELECTRICAL SPECIFICATION

2.1 Absolute Maximum Ratings

The followings are maximum values which, if exceed, may cause faulty operation or damage to the unit. The operational and non-operational maximum voltage and current values are listed in Table below.

Parameter	Symbol	Min.	Typ.	Max.	Unit	Remark
Power Supply Voltage (LCD Module)	V _{DD}	3.0	3.3	3.6	V	
Back-light Power Supply Voltage	HV _{DD}	17.7		20.7	V	
Back-light LED Current	I _{LED}		30		mA	
Operating Temperature	T _{OP}	-20		+70	°C	
Storage Temperature	T _{ST}	-30		+80	°C	Note

Note:

Temperature and relative humidity range are shown in the Figure below.

Wet bulb temperature should be 39°C max. and no condensation of water.

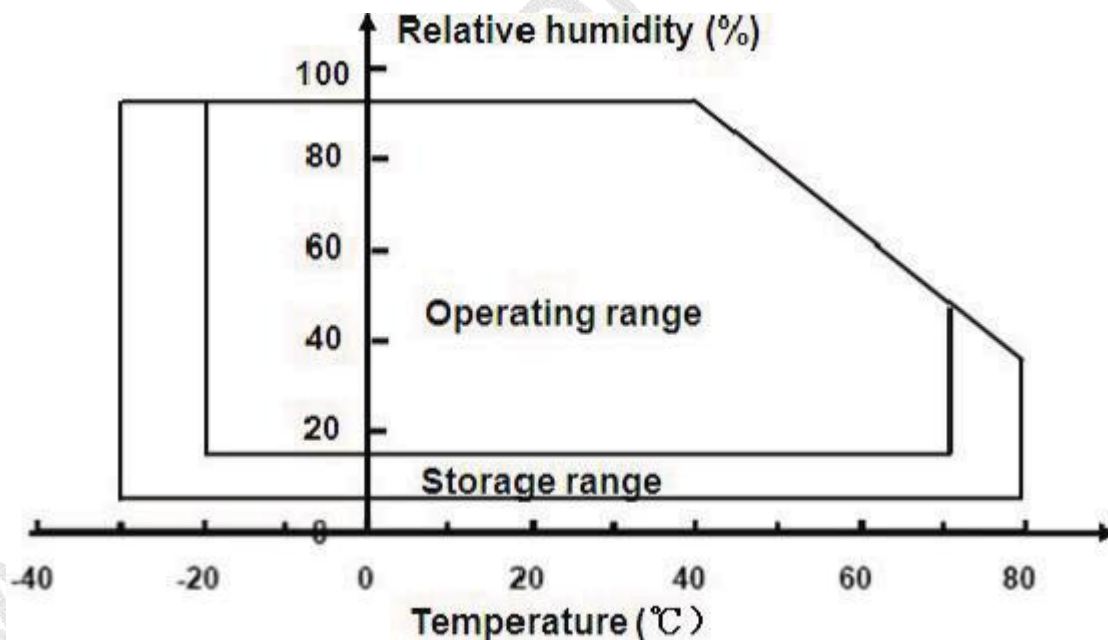

**2.2 Electrical specification**

Parameter	Symbol	Values			Unit	Note
		Min.	Typ.	Max.		
Power Supply Input Voltage	VDD	3.0	3.3	3.6	V	
Power Supply Current	IDD		480		mA	
Back-light Power Supply Voltage	HVDD			20.7	V	
Back-light Power Supply Current	IHVDD		120		mA	4 parallel * 6 string
Positive-going Input Threshold Voltage	VIT+			+100	mV	Vcom = 1.2V(typ.)
Negative-going Input Threshold Voltage	VIT-	-100			mV	
Differential input common mode voltage	Vcom		1.2		V	VIH=100mV, VIL=-100mV
Power Consumption	PD		1.6		W	Note 1
	PBL		2.484		W	Note 2
	PTotal		4.084		W	

2.3 Backlight Driving Conditions

Parameter		Min	Typ	Max	Unit	
LED Forward Voltage	V _F	17.4	19.2	20.4	V	-
LED Forward Current	I _F	-	30	-	mA	-
LED Power Consumption	P _{LED}	2.09	2.31	2.45	W	Note 1
LED Life Time	N/A	-	30,000	-	Hrs	IF = 30mA Note 2

Notes:

1. Calculator Value for reference $I_{LED} \times V_{LED} \times LED \text{ Quantity} = P_{LED}$
2. The LED Life-time define as the estimated time to 50% degradation of initial luminous.



2.4 Block Diagram

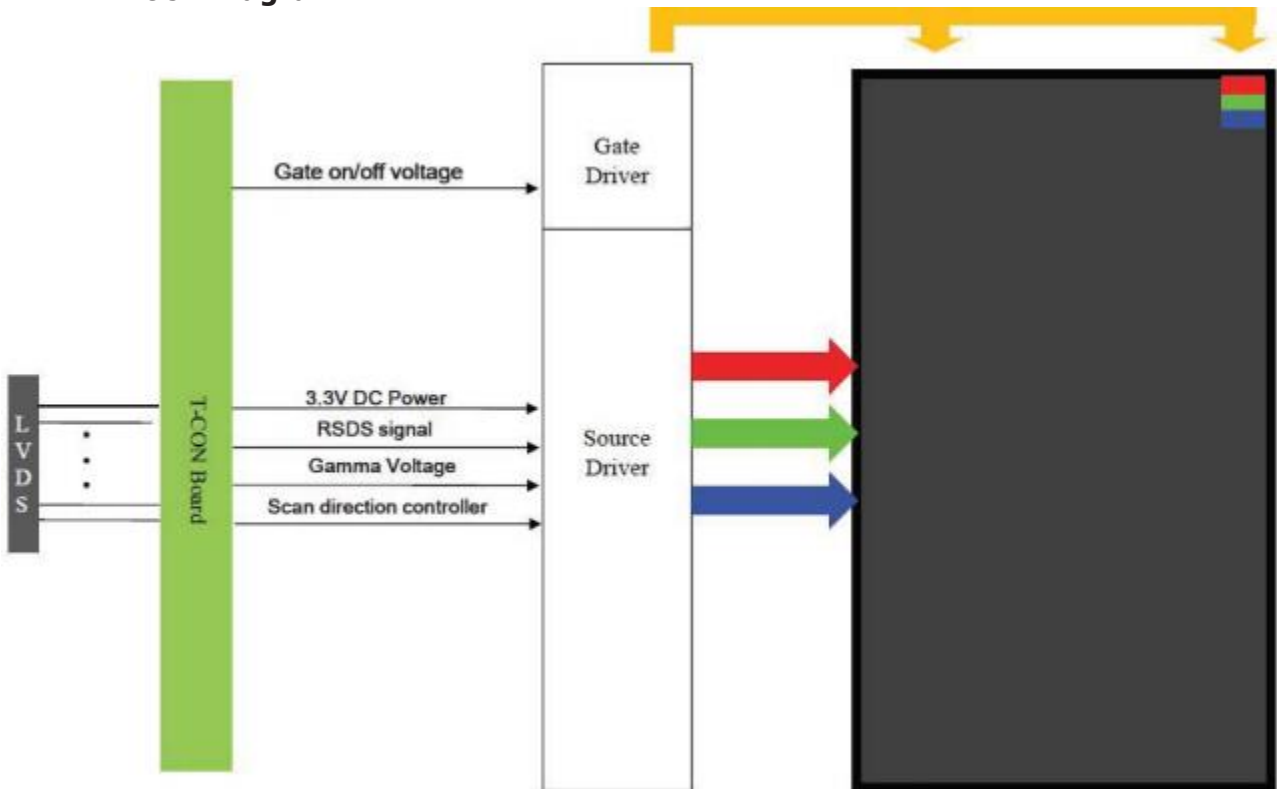

www.panet



2.5 INPUT SIGNALS, BASIC DISPLAY COLORS & GRAY SCALE OF COLORS

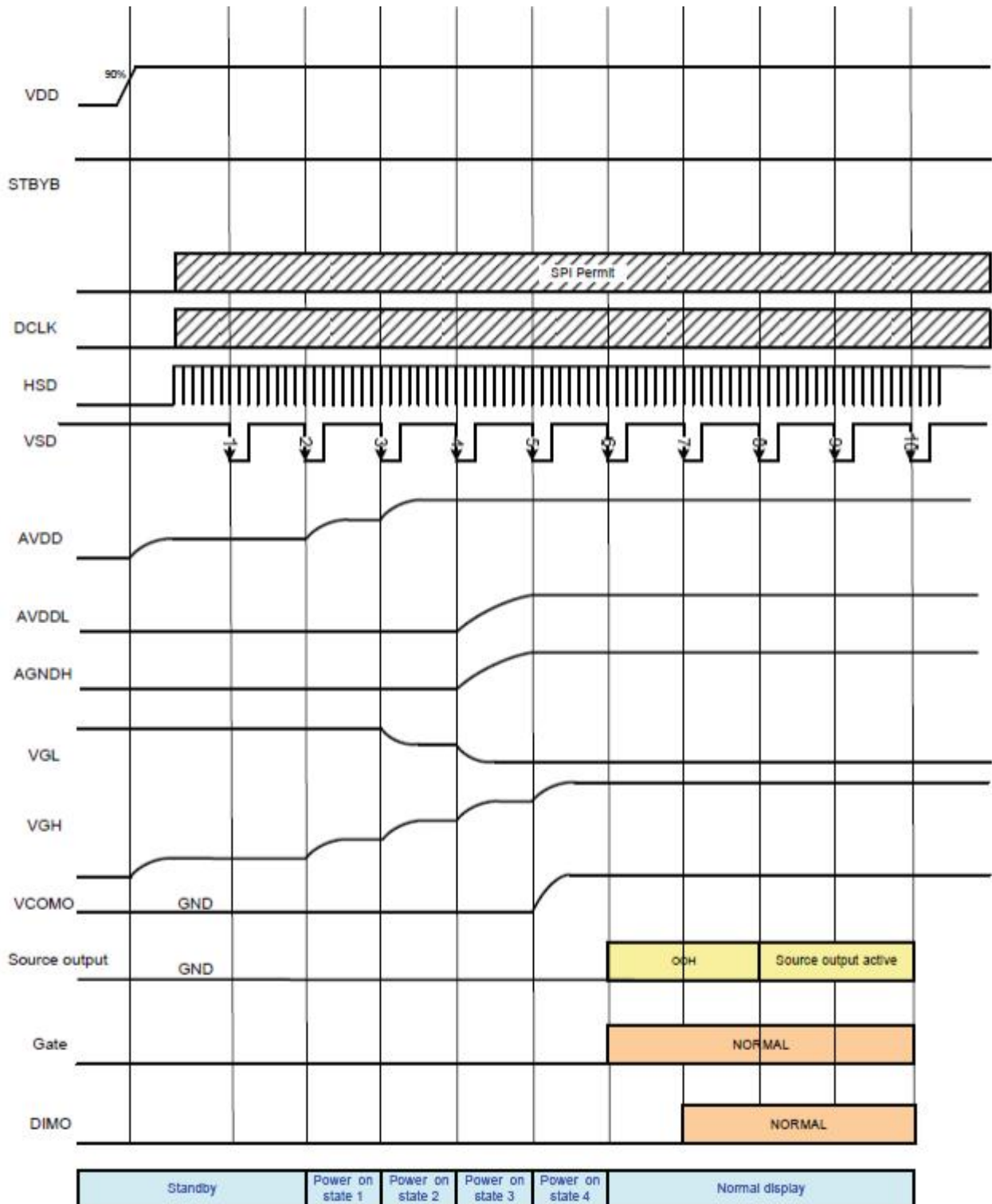



2.6 Power Sequence

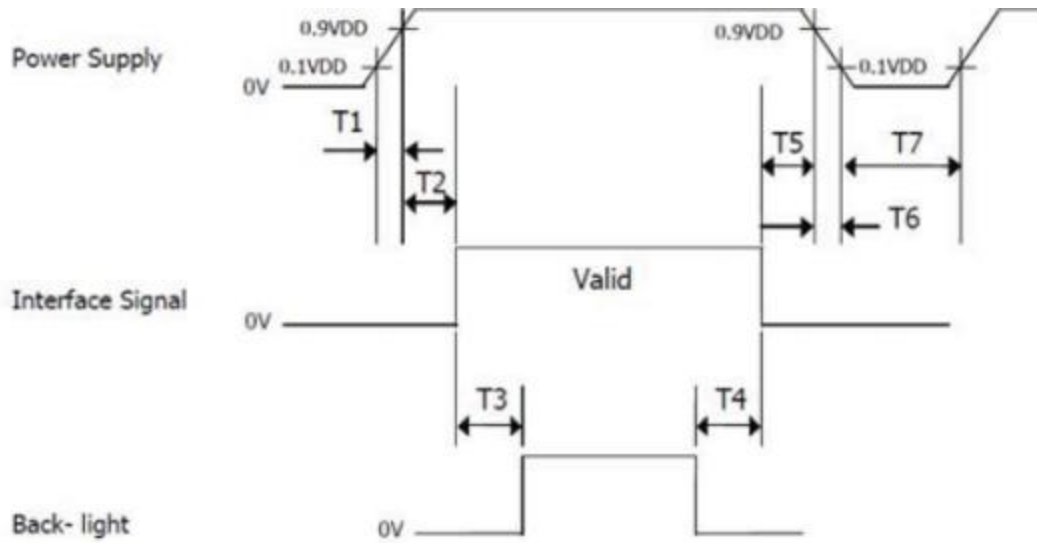

Parameter	Values			Units
	Min	Typ	Max	
T1	0.5	-	10	ms
T2	0	-	50	ms
T3	200	-	-	ms
T4	200	-	-	ms
T5	0.5	-	50	ms
T6	0	-	10	ms
T7	500	-	-	ms

www.f...



3.0 SIGNAL TIMING SPECIFICATION

3.1 The BA104S01-200 is operated by the DE only.

Parameter	Symbol	Min	Typ	Max	Unit
DCLK Frequency	fclk	32.6	39.6	62.4	MHz
Horizontal Display Area	thd	800			DCLK
HSD Period	th	900	1056	1300	DCLK
HSD Blanking	thb + thfp	90	200	500	DCLK
Vertical Display Area	tvd	600			TH
VSD Period	tv	610	630	800	TH
VSD Blanking	tvbp + tvfp	10	30	200	TH

DE mode (800 x 600)

3.2 LVDS Rx Interface Timing Parameter

The specification of the LVDS Rx interface timing parameter is shown below.

Parameter	Symbol	Min	Typ	Max	Unit	Condition
Clock frequency	RXFCLK	20	-	85	MHz	-
Input data skew margin	TRSKM	-600	-	+600	pS	VID =200mV RXVCM =1.2V RXFCLK = 65MHz
Clock high time	TLVCH	-	$4/(7 * \text{RXFCLK})$	-	ns	-
Clock low time	TLVCL	-	$3/(7 * \text{RXFCLK})$	-	ns	-
PLL wake-up time	TemPLL	-	-	150	μs	-



LVDS mode AD electrical characteristics

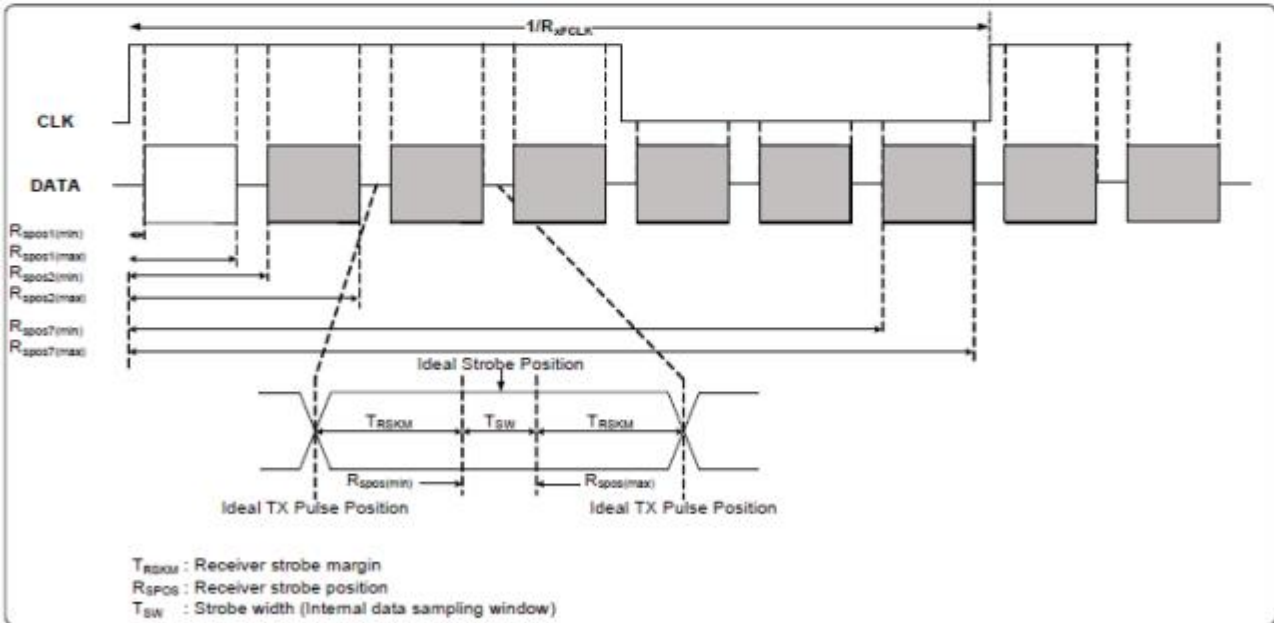
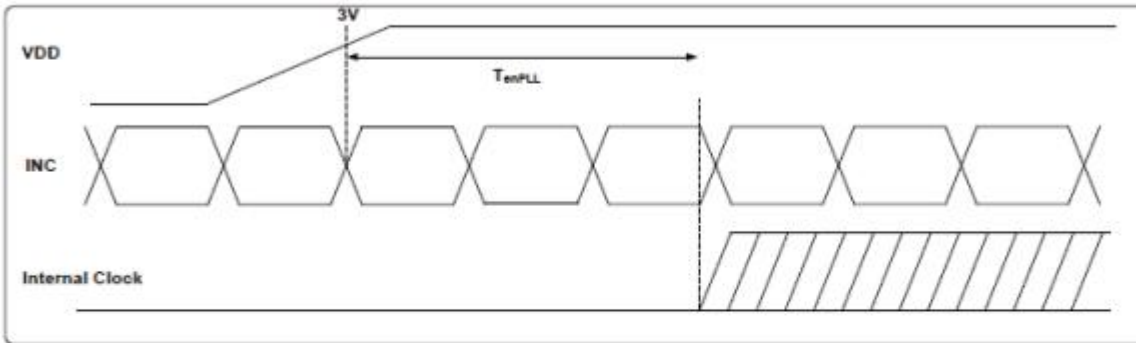
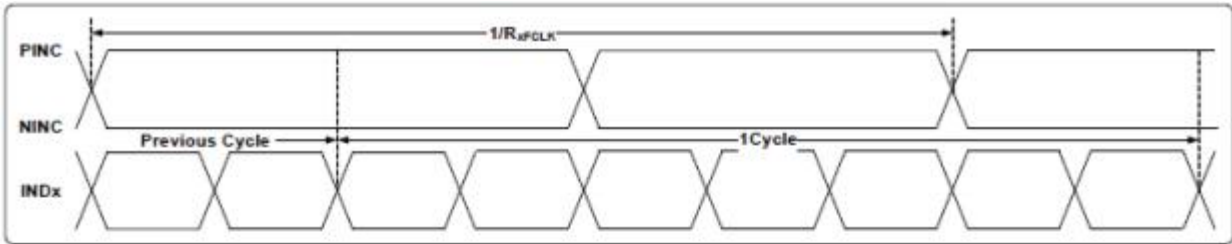



3.3 Signal timing waveforms of Interface Signal

a. Input Clock and Data Timing Diagram

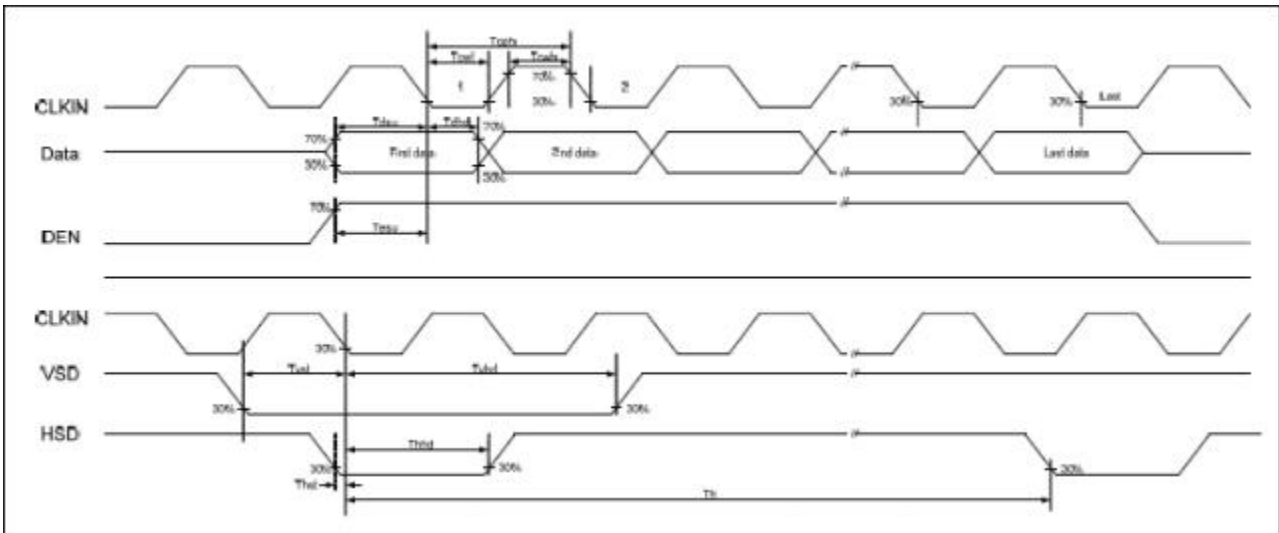

b. Source Output Timing Diagram

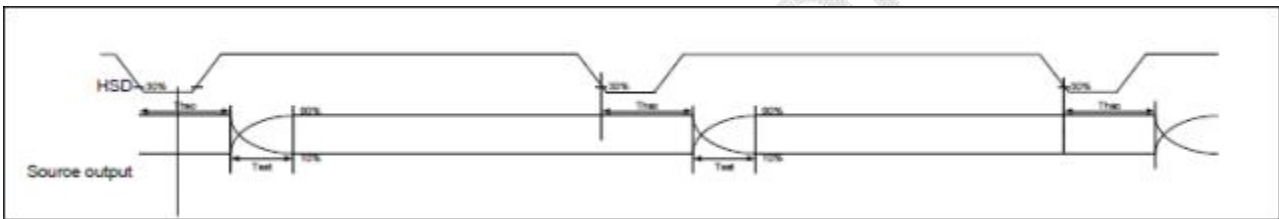

Source output timing diagram

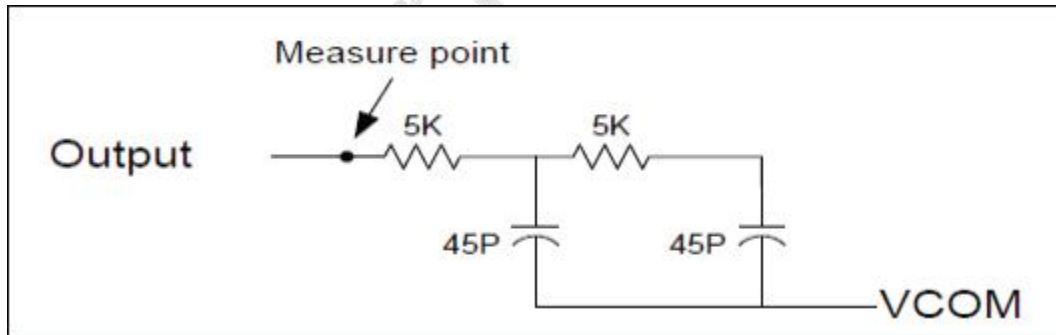

Output load condition



4.0 INTERFACE CONNECTION

4.1 Electrical Interface Connection

The electronics interface connector is STM MSB24013P20 or compatible. The connector interface pin assignments are listed below.

Pin	Symbol	Function
1	VDD	Logic Power 3.3V (Panel logic)
2	VDD	Logic Power 3.3V (Panel logic)
3	GND	Ground
4	GND	Ground
5	IN0-	LVDS receiver negative signal channel 0
6	IN0+	LVDS receiver positive signal channel 0
7	GND	Ground
8	IN1-	LVDS receiver negative signal channel 1
9	IN1+	LVDS receiver positive signal channel 1
10	GND	Ground
11	IN2-	LVDS receiver negative signal channel 2
12	IN2+	LVDS receiver positive signal channel 2
13	GND	Ground
14	CLK-	LVDS receiver negative signal clock
15	CLK+	LVDS receiver positive signal clock
16	GND	Ground
17	IN3-	LVDS receiver negative signal channel 3 (NC for 6bit LVDS input)
18	IN3+	LVDS receiver positive signal channel 3 (NC for 6bit LVDS input)
19	GND	Ground
20	SEL68	6/8bits LVDS data input selection [H: 8bit L/NC: 6bit]

Note 1: High stands for “2.7--3.3V” , Low stands for “0--0.4” .



4.2 LVDS Input signal

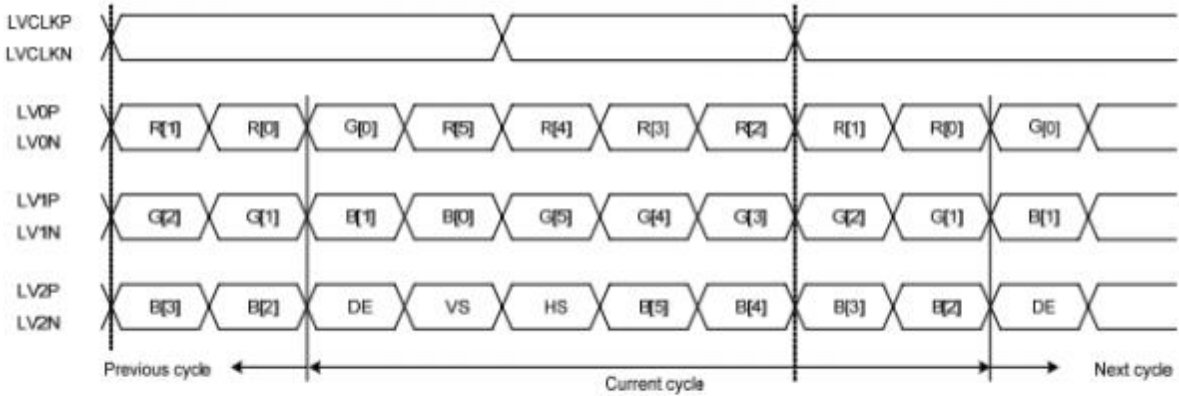

6-bit LVDS input data mapping

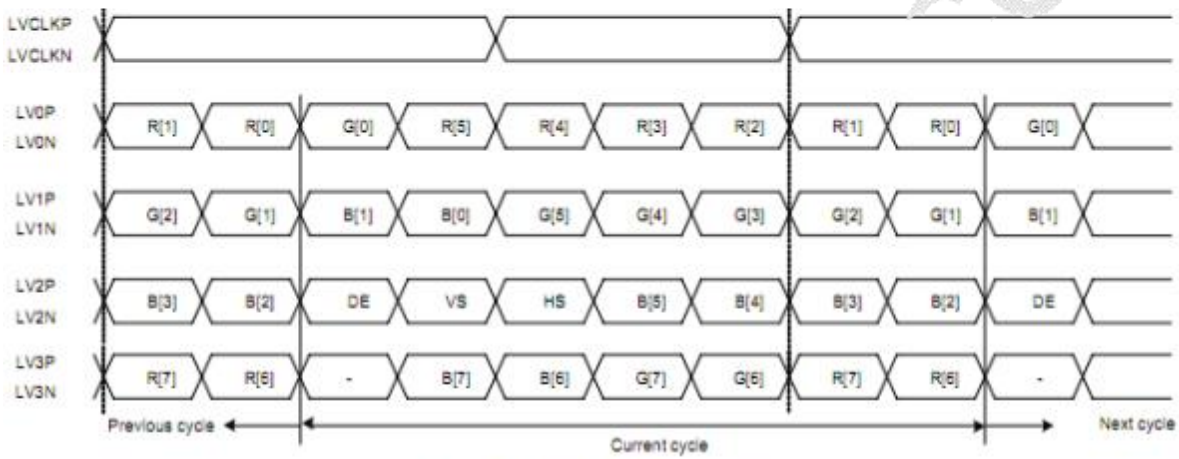

8-bit LVDS input data mapping

4.3 Data Input Format

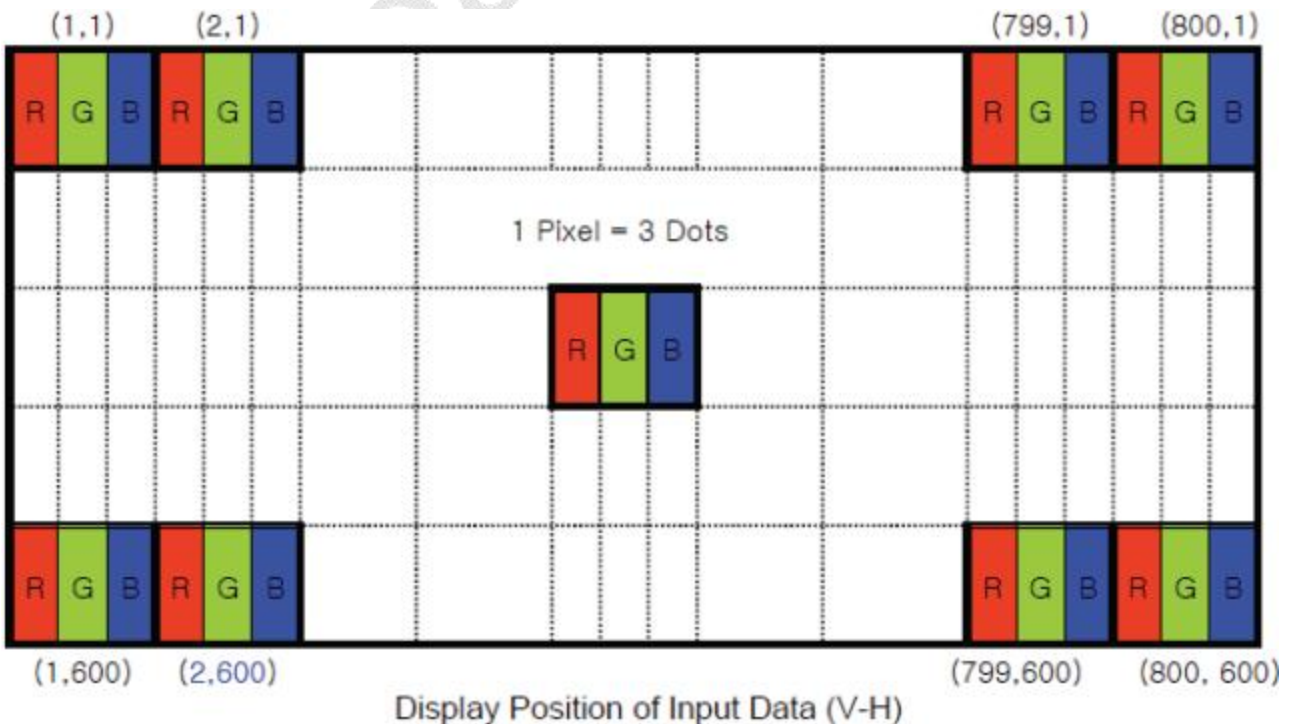



5.0 OPTICAL SPECIFICATIONS

5.1 Overview

The test of Optical specifications shall be measured in a dark room (ambient luminance ≤ 1 lux and temperature = $25 \pm 2^\circ\text{C}$) with the equipment of Luminance meter system (Topcon SR-UL1R and Westar TRD-100A) and test unit shall be located at an approximate distance 50cm from the LCD surface at a viewing angle of θ and Φ equal to 0° . The center of the measuring spot on the Display surface shall stay fixed.

The backlight should be operating for 30 minutes prior to measurement. Optimum viewing angle direction is 12 o'clock.

5.2 Optical Specifications

Parameter		Symbol	Condition	Min.	Typ.	Max.	Unit	Remark
Threshold Voltage		Vsat		2.0	2.2	2.4	V	Fig.1
		Vth		1.1	1.3	1.5	V	
Viewing Angle	Horizontal	θ_3	CR > 10	60	70		°	Note 1
		θ_9		60	70		°	
	Vertical	θ_{12}		50	60		°	
		θ_6		60	70		°	
Contrast Ratio		CR	$\theta = 0^\circ$	600	800			Note 2
Luminance		cd/m ²	$\theta = 0^\circ$	250	300		lm	Note 3
Uniformity		%	$\theta = 0^\circ$	70%	80%			Note 4
NTSC		%	$\theta = 0^\circ$		50%			
Reproduction Of color	Red	Rx	$\theta = 0^\circ$		TBD			Note 5 *Module
		Ry			TBD			
	Green	Gx			TBD			
		Gy			TBD			
	Blue	Bx			TBD			
		By			TBD			
White		Wx	$\theta = 0^\circ$		TBD			
		Wy			TBD			
Response Time		Tr+ Tf	$\theta = 0^\circ$		30		ms	Note 6

Note:

- Viewing angle is the angle at which the contrast ratio is greater than 10. The viewing are determined for the horizontal or 3, 9 o'clock direction and the vertical or 6, 12 o'clock direction with respect to the optical axis which is normal to the LCD surface (see FIG.2).
- Contrast measurements shall be made at viewing angle of $\theta = 0^\circ$. and at the center of the LCD surface. Luminance shall be measured with all pixels in the view field set first to white, then to the dark (black) state. (See FIG. 2) Luminance Contrast Ratio (CR) is defined mathematically.



$$CR = \frac{\text{Luminance when displaying a white raster}}{\text{Luminance when displaying a black raster}}$$

3. Surface luminance is the center point across the LCD surface 50cm from the surface with all pixels displaying white. This measurement shall be taken at the locations shown in FIG. 2.

4. Uniformity measurement shall be taken at the locations shown in FIG. 2&3, for a total of the measurements per display, measure surface luminance of these nine points across the LCD surface 50cm from the surface with all pixels displaying white.

$$\text{Uniformity} = \frac{\text{Min Luminance of 9 points}}{\text{Max Luminance of 9 points}} \times 100\%$$

5. The color chromaticity coordinates specified in Table1 shall be calculated from The spectral data measured with all pixels first in red, green, blue and white. Measurements shall be made at the center of the Module.

6. The electro-optical response time measurements shall be made as FIG.4 by switching the "data" input signal ON and OFF.

The times needed for the luminance to change from 10% to 90% is Tr and 90% to 10% is Tf.

Figure 1. The definition of Vth & Vsat

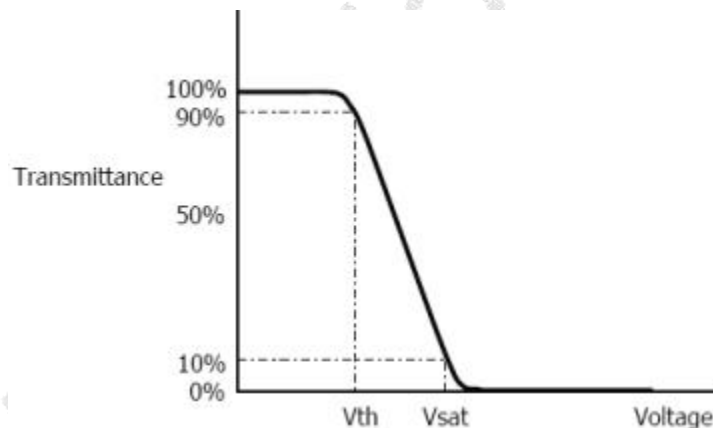

Figure 2. Measurement Set Up

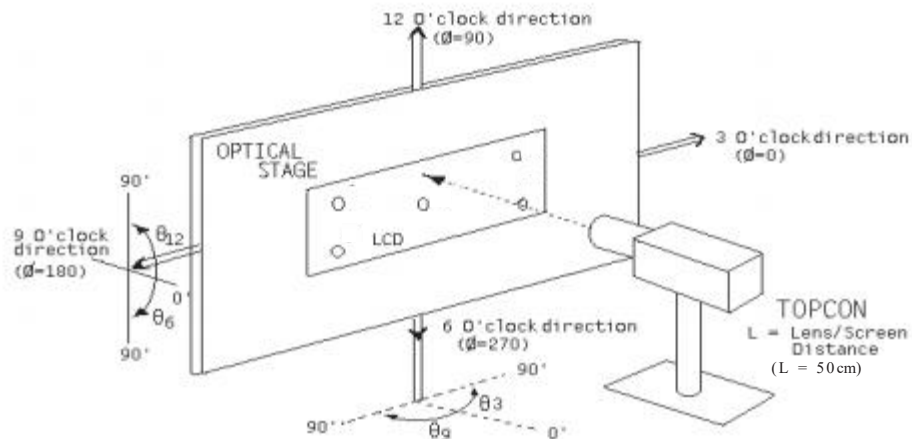



Figure 3. Uniformity Measurement Locations

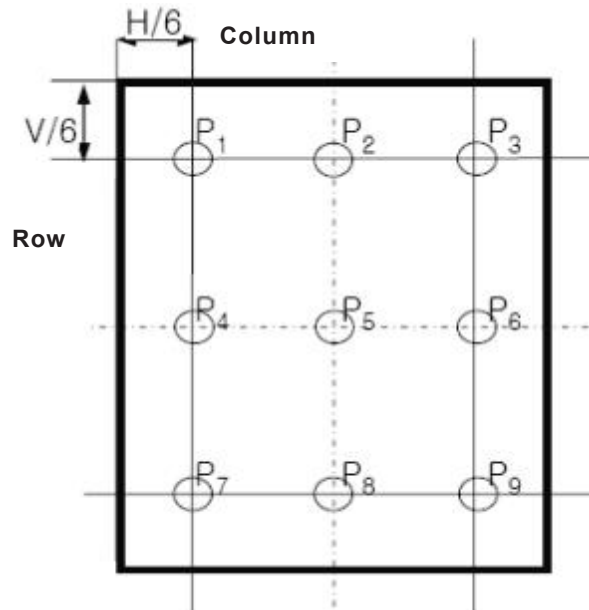
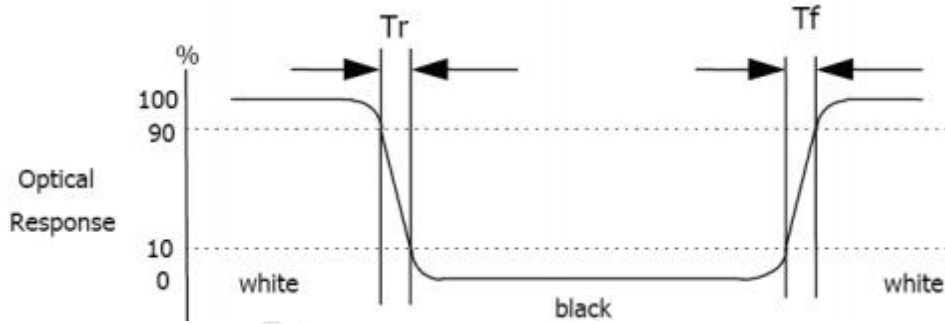

Figure 4. Response Time Testing





6.0 MECHANICAL CHARACTERISTICS

6.1 Dimension Requirements

Mechanical outlines for the panel (H: horizontal length, V: vertical length)

Parameter	Specification	Unit	Remark
Panel size	221.6(H) × 171(V)	mm	
CF size	218.4(H) × 165.4(V)	mm	
Active area	211.2(H) × 158.4(V)	mm	
Number of pixels	800(H)RGB × 600(V)	pixels	
	(1 pixel = R + G + B dots)		
Pixel pitch	0.264(H) × 0.264(V)	mm	
Pixel arrangement	RGB Vertical stripe		
Panel ID	10 × 2	mm	
COG pad area	5.6(Source), 3.2(Gate)	mm	
D-IC to FPC distance	0.5(Source)	mm	Note
D-IC width	1.07(Source), 0.67(Gate)	mm	
D-IC to CF edge	2.83(Source), 1.87(Gate)	mm	
FPC to Glass edge	0.3(Source)	mm	
FPC width	0.9(Source)	mm	
Seal Area (U/D/L/R)	3.5/3.5/3.6/3.6	mm	
Dimensional outline	236(H) × 176.9(V) × 5.6(D)	mm	
Display mode	Normally white		

Note:

The size specified is calculated by IC-driver HX8245(Source) + HX8677(Gate), the size maybe changed if customer use other IC.



Figure 5. LCM Outline Dimension (unit:mm)

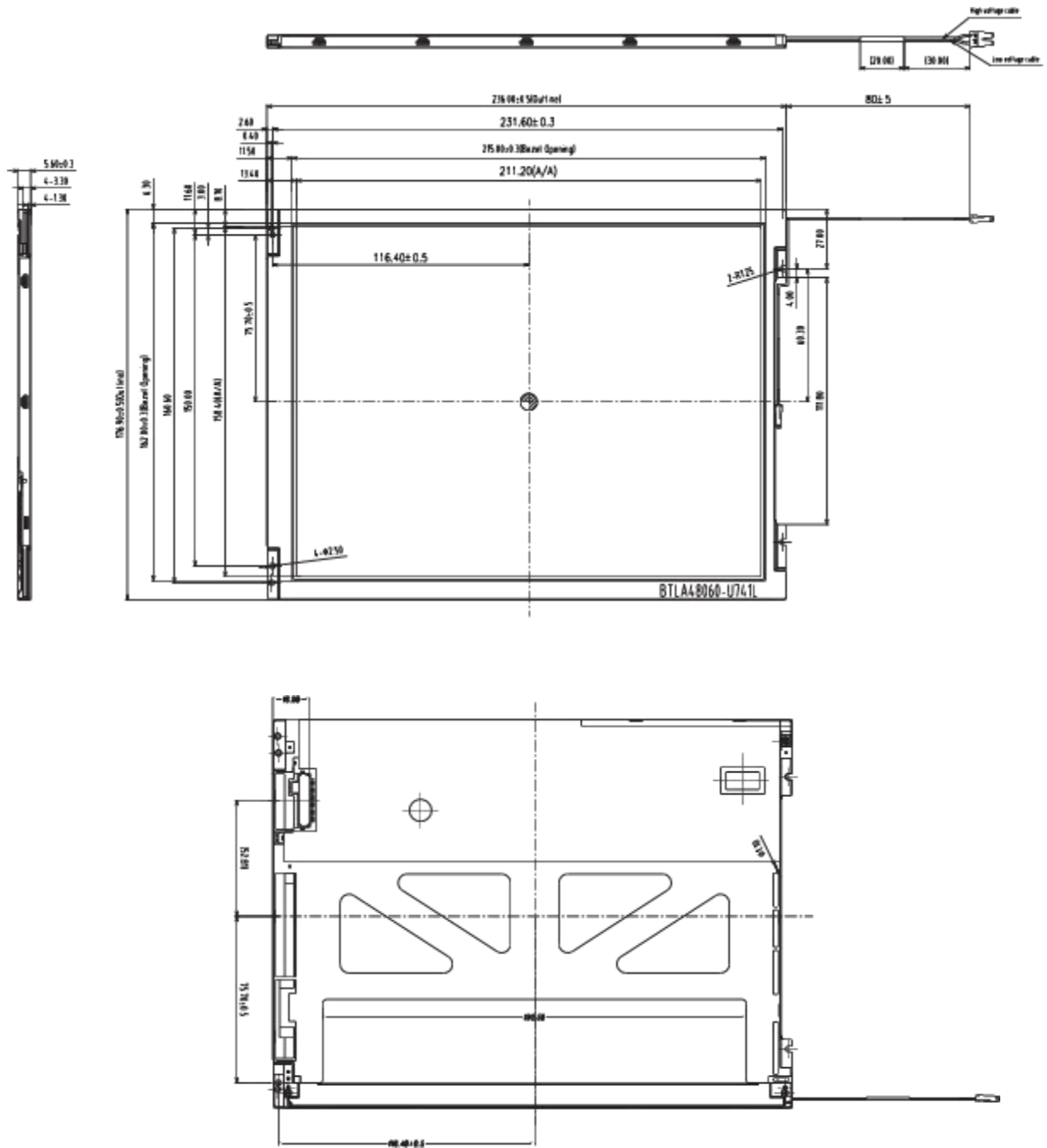
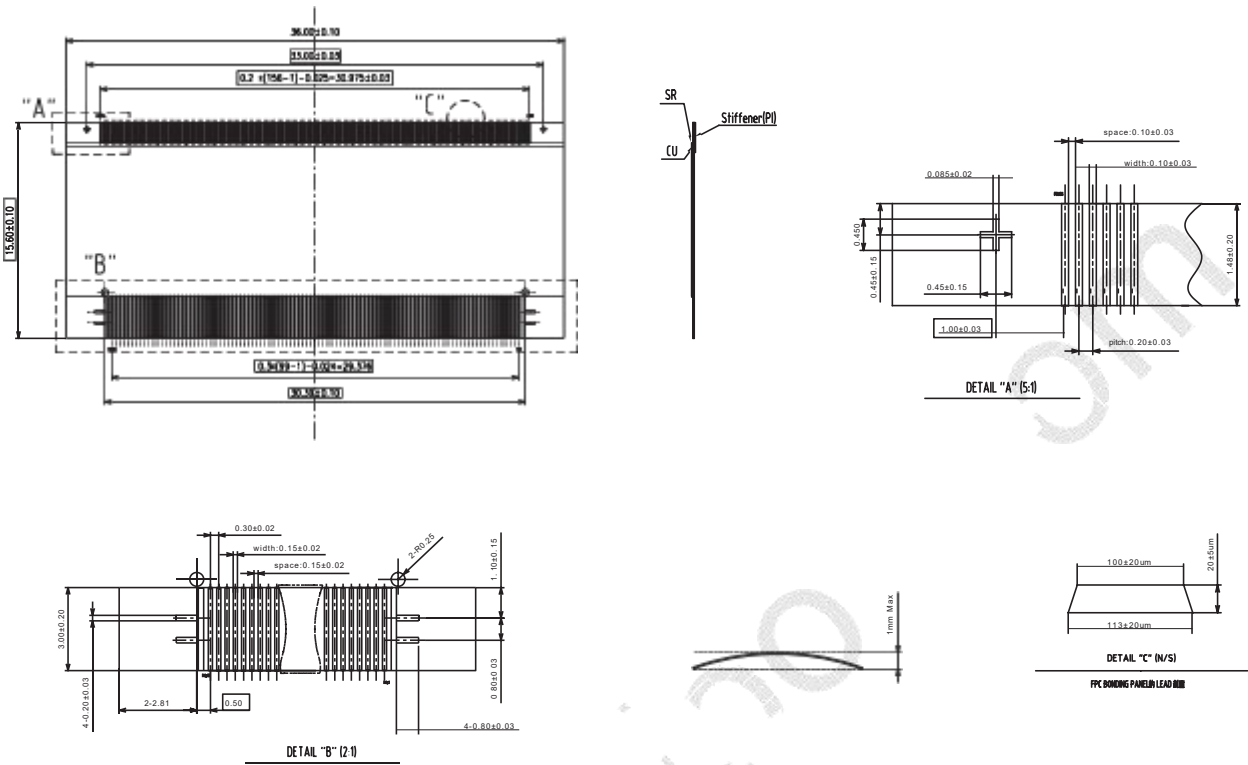

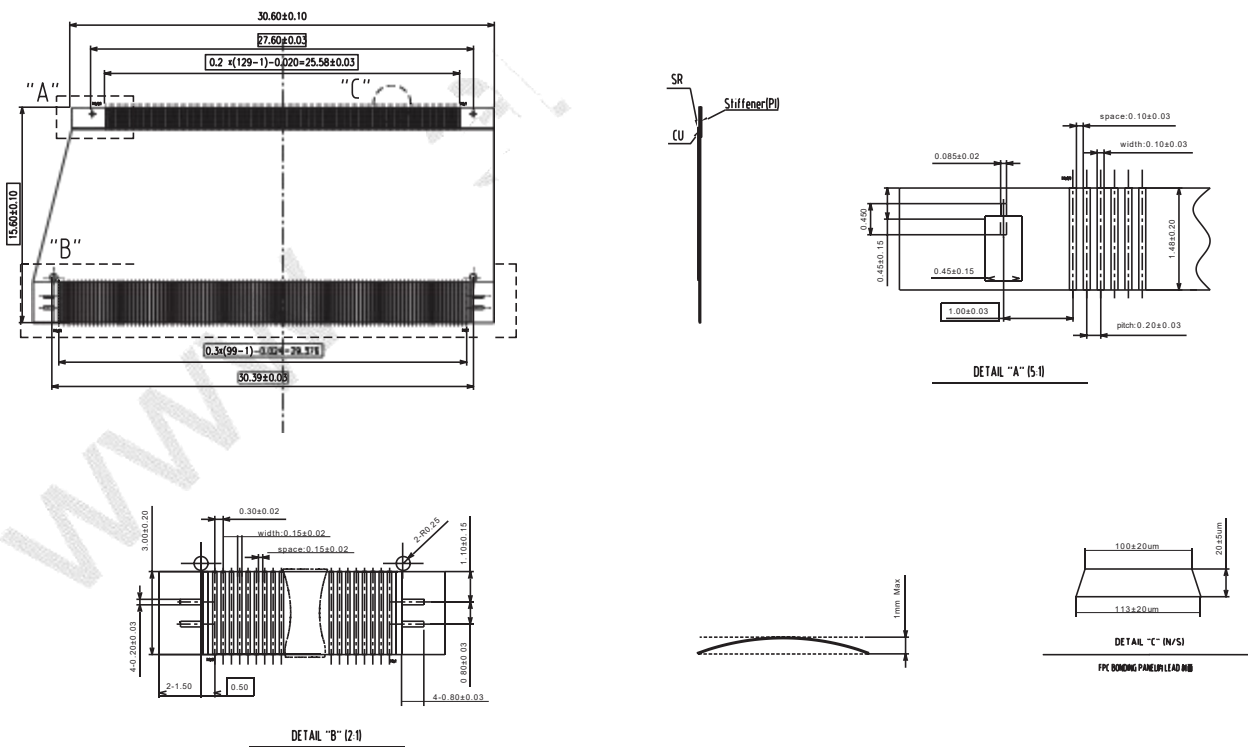

Figure 6. FPC main structure (unit:mm)

FPCA



FPCB



**7.0 RELIABILITY TEST**

NO.	Test Item	Test Condition	Duration
1	High temperature, high humidity operation test(THO)	60 °C, 90%RH	240hrs
2	Low temperature operation test(LTO)	-20 °C	240hrs
3	High temperature operation test(HTO)	70 °C	240hrs
4	High temperature storage test(HTS)	80 °C	240hrs
5	Low temperature storage test(LTS)	-30 °C	240hrs
6	Thermal shock test (TST)	-20 °C→70 °C (Per 30min)	100hrs
7	Altitude test(ALT)	25 °C,40000ft	12hrs
8	On/Off	On 30s / Off 30s	3000times
9	PCT	121 °C,2ATM ,100%RH	12hr
10	ESD	150pF 330Ω ±8KV(Air) / ±6KV(Contact)	20points
11	Vibration	1.5G ,10/500/10,Sine,X/Y/ Z Direction	Total:30min



8.0 PACKING METHOD

NO.	Item	Model(material)	Dimension(mm)	Unit Weight(Kg)	Quantity(ea/inner box)	Remark
1	LCM Module	BA104S01-200	236.0×176.9×5.6	0.292	25	
2	Anti-static Bag	PE	246×216.9×0.07	0.009	25	
3	Inner Box	Corrugated Paper	510×350×252	2.33	1	Other parts' quantity is given in accordance with this baseline
Weight-1	9.9Kg±10%					Each inner box's LCM
4	Outer Box	Corrugated Paper	1050×725×756	2.44	1/12	2×2 inner boxes/each layer,total 3 layers;
5	Cover	Corrugated Paper	1065×733×120	1.02	1/12	Then add outer box and cover.
Weight-2	121.7Kg±10%					Each outer box's LCM

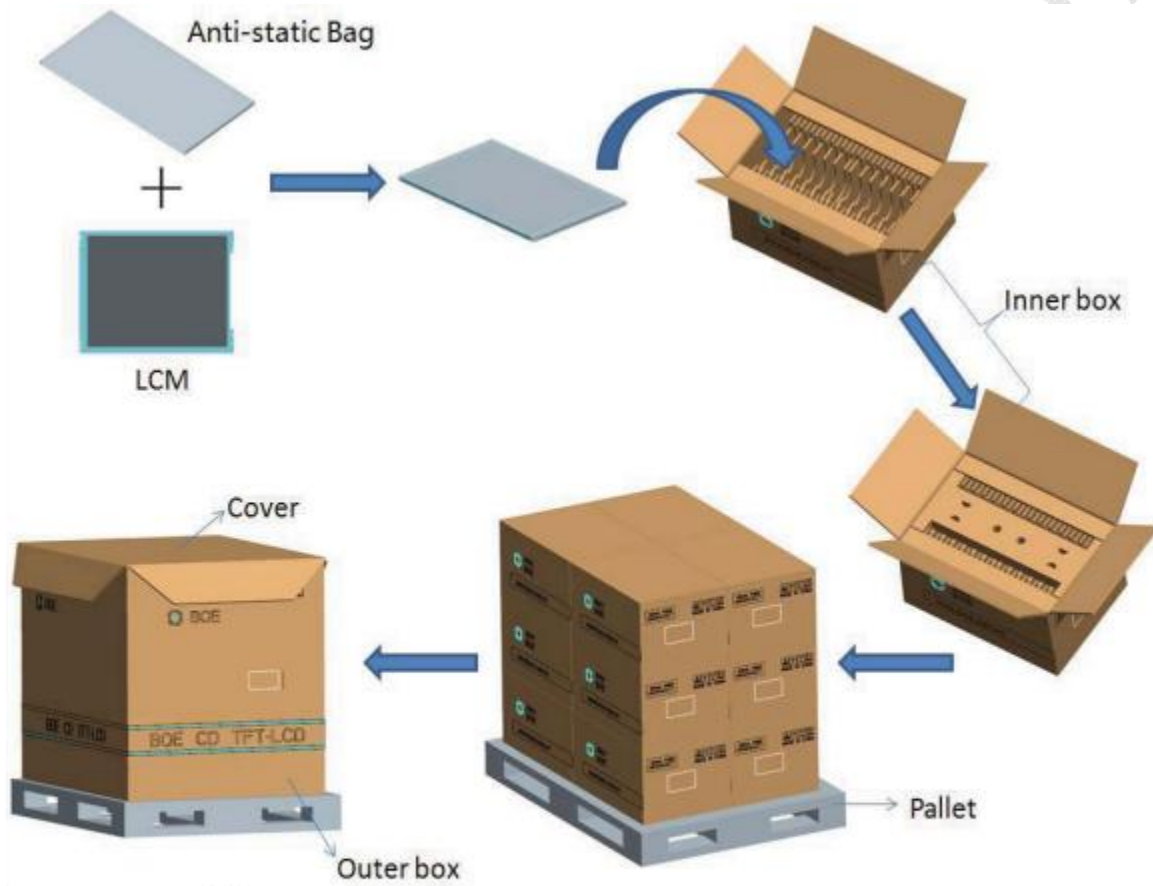



9.0 PRODUCT ID RULE

(1) Product label

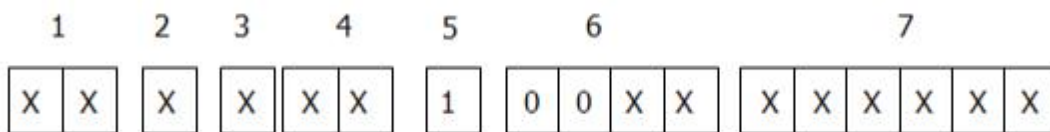

Type designation

No 1. Control Number

No 2. Rank / Grade

No 3. Line classification ("P03"-C, Others-A)

No 4. Year (09 : 2009, 10: 2010, ...)

No 5. Month (1, 2, 3, ..., 9, X, Y, Z)

No 6. Last four bits Product Identification (FG)

No 7. Serial Number (0-9, A-F)

(2) High voltage caution label

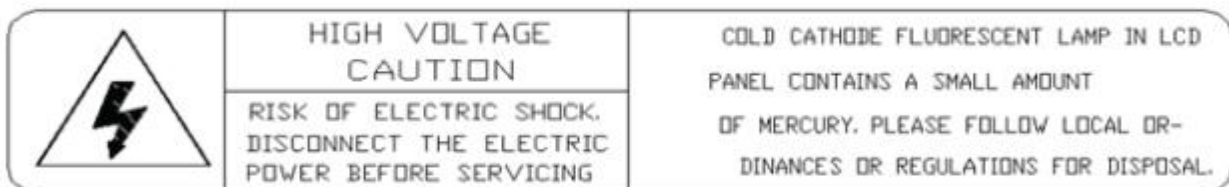

(3) Box label

Label Size: 110 mm (L) × 56 mm (W)

Contents

Model: BA104S01-200

Q' ty: Module Q' ty in one box

Serial No.: Box Serial No. See next Figure for detail description.

Date: Packing Date

Internal use of Product



00	0	0	00	0	0000	000000
Type	Grade	Line	Year	Month	Internal use	Serial No



10.0 HANDLING & CAUTIONS

10.1 Mounting Method

- The panel of the LCD consists of two thin glasses with polarizer which easily get damaged. So extreme care should be taken when handling the LCD.
- Excessive stress or pressure on the glass of the LCD should be avoided. Care must be taken to insure that no torsional or compressive forces are applied to the LCD unit when it is mounted.
- If the customer's set presses the main parts of the LCD, the LCD may show the abnormal display. But this phenomenon does not mean the malfunction of the LCD and should be pressed by the way of mutual agreement.
- To determine the optimum mounting angle, refer to the viewing angle range in the specification for each model.
- Mount a LCD module with the specified mounting parts.

10.2 Caution of LCD Handling and Cleaning

- Since the LCD is made of glass, do not apply strong mechanical impact or static load onto it. Handling with care since shock, vibration, and careless handling may seriously affect the product. If it falls from a high place or receives a strong shock, the glass maybe broken.
- The polarizer on the surface of panel are made from organic substances. Be very careful for chemicals not to touch the polarizer or it leads the polarizer to be deteriorated.
- If the use of a chemical is unavoidable, use soft cloth with solvent recommended below to clean the LCD's surface with wipe lightly.
-IPA (Isopropyl Alcohol), Ethyl Alcohol, Tri-chloro, tri-florothane.
- Do not wipe the LCD's surface with dry or hard materials that will damage the polarizer and others. Do not use the following solvent—Water, acetone, Aromatics.
- It is recommended that the LCD be handled with soft gloves during assembly, etc.
The polarizer on the LCD's surface are vulnerable to scratch and thus to be damaged by shape particles.
- Do not drop water or any chemicals onto the LCD's surface.
- A protective film is supplied on the LCD and should be left in place until the LCD is required for operation.
- The ITO pad area needs special careful caution because it could be easily corroded. Do not contact the ITO pad area with HCFC, Soldering flux, Chlorine, Sulfur, saliva or fingerprint. To prevent from the ITO corrosion, customers are recommended that the ITO area would be covered by UV or silicon.
- Please handle FPC with care.



10.3 Caution Against Static Charge

- The LCD modules use C-MOS LSI drivers, so customers are recommended that any unused input terminal would be connected to Vdd or Vss, do not input any signals before power is turn on, and ground you body, work/assembly area, assembly equipments to protect against static electricity.
- Remove the protective film slowly, keeping the removing direction approximate 30-degree not vertical from panel surface, if possible, under ESD control device like ion blower, and the humidity of working room should be kept over 50%RH to reduce the risk of static charge.
- Avoid the use work clothing made of synthetic fibers. We recommend cotton clothing or other conductivity-treated fibers.
- In handling the LCD, wear non-charged material gloves. And the conducting wrist to the earth and the conducting shoes to the earth are necessary.

10.4 Caution For Operation

- It is indispensable to drive the LCD within the specified voltage limit since the higher voltage than the limit causes the shorter LCD's life. An electro-chemical reaction due to DC causes undesirable deterioration of the LCD so that the use of DC drive should avoid.
- Do not connect or disconnect the LCD to or from the system when power is on.
- Never use the LCD under abnormal conditions of high temperature and high humidity.
- When expose to drastic fluctuation of temperature(hot to cold or cold to hot), the LCD may be affected; specifically, drastic temperature fluctuation from cold to hot, produces dew on the LCD's surface which may affect the operation of the polarizer on the LCD.
- Response time will be extremely delayed at lower temperature than the operating temperature range and on the other hand LCD may turn black at temperature above its operational range. However those phenomenon do not mean malfunction or out of order with the LCD. The LCD will revert to normal operation once the temperature returns to the recommended temperature range for normal operation.
- Do not display the fixed pattern for a long time because it may develop image sticking due to the LCD structure. If the screen is displayed with fixed pattern, use a screen saver.
- Do not disassemble and/or re-assemble LCD module

10.5 Packaging

- Modules use LCD element, and must be treated as such.
 - Avoid intense shock and falls from a height.
 - To prevent modules from degradation, do not operate or store them exposed directly to sunshine or high temperature/humidity for long periods.



10.6 Storage

- A slight dew depositing on terminals is a cause for electro-chemical reaction resulting in terminal open circuit. Relative humidity of the environment should therefore be kept below 60%RH.
- Original protective film should be used on LCD's surface (polarizer). Adhesive type protective film should be avoided, because it may change color and/or properties of the polarizer.
- Do not store the LCD near organic solvents or corrosive gasses.
- Keep the LCD safe from vibration, shock and pressure.
- Black or white air-bubbles may be produced if the LCD is stored for long time in the lower temperature or mechanical shocks are applied onto the LCD.
- In the case of storing for a long period of time for the purpose or replacement use, the following ways are recommended.
 - Store in a polyethylene bag with sealed so as not to enter fresh air outside in it.
 - Store in a dark place where neither exposure to direct sunlight nor light is.
 - Keep temperature in the specified storage temperature range.
 - Store with no touch on polarizer surface by the anything else. If possible, store the LCD in the packaging situation when it was delivered.

10.7 Safety

- For the crash damaged or unnecessary LCD, it is recommended to wash off liquid crystal by either of solvents such as acetone and ethanol and should be burned up later.
- In the case of LCD is broken, watch out whether liquid crystal leaks out or not. If your hands touch the liquid crystal, wash your hands cleanly with water and soap as soon as possible.
- If you should swallow the liquid crystal, first, wash your mouth thoroughly with water, then drink a lot of water and induce vomiting, and then, consult a physician.
- If the liquid crystal get in your eyes, flush your eyes with running water for at least fifteen minutes.
- If the liquid crystal touches your skin or clothes, remove it and wash the affected part of your skin or clothes with soap and running water.

11.0 Applicable Scope

- This product specification only applies to the products manufactured and sold by our company.
- Any specification, quality etc. about other parts mentioned in this product spec are no concern of our company.