



PRODUCT SPECIFICATION

Doc. Number :

- Tentative Target Specification
- Preliminary Specification
- Approval Specification

MODEL NO.: G070ACE
SUFFIX: LH1

Customer:	
APPROVED BY	SIGNATURE
Name / Title _____ Note	_____
_____ Please return 1 copy for your confirmation with your signature and comments.	

Approved By	Checked By	Prepared By



1. GENERAL DESCRIPTION.....	5
1.1 OVERVIEW.....	5
1.2 FEATURES.....	5
1.3 APPLICATION.....	5
1.4 GENERAL SPECIFICATIONS.....	5
1.5 MECHANICAL SPECIFICATIONS.....	6
2. ABSOLUTE MAXIMUM RATINGS.....	7
2.1 ABSOLUTE RATINGS OF ENVIRONMENT.....	7
2.2 ELECTRICAL ABSOLUTE RATINGS.....	8
2.2.1 TFT LCD MODULE.....	8
2.2.2 LED CONVERTER.....	8
3. ELECTRICAL CHARACTERISTICS.....	9
3.1 LCD ELETRONICS SPECIFICATION.....	9
3.2 BACKLIGHT UNIT.....	12
4. ELECTRICAL SPECIFICATIONS.....	14
4.1 TFT LCD MODULE.....	14
5. INTERFACE CONNECTIONS.....	15
5.1 TFT LCD MODULE.....	15
5.2. COLOR DATA INPUT ASSIGNMENT.....	17
6. INTERFACE TIMING.....	18
6.1 INPUT SIGNAL TIMING SPECIFICATIONS.....	18
6.2 POWER ON/OFF SEQUENCE.....	20
6.3 The Input Data Format.....	21
6.4 Scanning Direction.....	23
7. OPTICAL CHARACTERISTICS.....	24
7.1 TEST CONDITIONS.....	24
7.2 OPTICAL SPECIFICATIONS.....	24
8. RELIABILITY TEST ITEM.....	27
9. PACKING.....	28
9.1 PACKING SPECIFICATIONS.....	28
9.2 PACKING METHOD.....	28
9.3 UN-PACKING METHOD.....	29
10. MODULE LABEL.....	30
10.1 INX MODULE LABEL.....	30
PRECAUTIONS	31

CONTENTS



PRODUCT SPECIFICATION

11.

11.1 ASSEMBLY AND HANDLING PRECAUTIONS..... 31

11.2 STORAGE PRECAUTIONS.....31

11.3 OTHER PRECAUTIONS..... 32

12. MECHANICAL CHARACTERISTIC..... 33

Appendix . SYSTEM COVER DESIGN NOTICE.....34



REVISION HISTORY

Version	Date	Page	Description
0.0	Sep.6, 2019	All	Spec Ver. 0.0 was first issued.



1. GENERAL DESCRIPTION

1.1 OVERVIEW

G070ACE-LH1 is a 7" TFT Liquid Crystal Display module with WLED Backlight unit and 30 pins 1ch-LVDS interface. This module supports 800xRGBx480 AAS mode and can display 262k or 16.7M colors. The PSWG is to establish a set of displays with standard mechanical dimensions and select electrical interface requirements for an industry standard 7" WVGA LCD panel and the LED driving device for Backlight is built in PCBA.

1.2 FEATURES

- Excellent brightness (1000 nits)
- Ultra high contrast ratio (800:1)
- Fast response time ($T_R + T_F = 25$ ms)
- WXGA (800 x 480 pixels) resolution
- DE (Data Enable) only mode
- LVDS (Low Voltage Differential Signaling) interface
- PSWG (Panel Standardization Working Group)
- Ultra wide viewing angle: 169(H)/ 169(V) (CR>10) AAS technology
- 180 degree rotation display option
- Wide operation temperature

1.3 APPLICATION

- TFT LCD monitor
- Industrial applications

1.4 GENERAL SPECIFICATIONS

Item	Specification	Unit	Note
Screen Size	7" real diagonal		
Driver Element	a-si TFT active matrix	-	-
Pixel Number	800 x R.G.B. x 480	pixel	-
Pixel Pitch	0.1905 (H) x 0.1905 (V)	mm	-
Pixel Arrangement	RGB stripe	-	-
Display Colors	16.7M / 262K	color	-
Transmissive Mode	Normally Black	-	-
Surface Treatment	AG type, 3H hard coating,	-	-
Luminance, White	1000(Typ.)	Cd/m ²	
Color Gamut	70 % of NTSC(Typ.)	-	-
Power Consumption	(Total 3.98 W (Typ) @ cell 0.48 W (Typ), BL 3.5 W (Typ))		

Note (1)Please refer to the attached drawings for more information of front and back outline imensions



PRODUCT SPECIFICATION

1.5 MECHANICAL SPECIFICATIONS

Item		Min.	Typ.	Max.	Unit	Note
Module Size	Horizontal (H)	169.5	170	170.5	mm	(1) (2)
	Vertical (V)	109.5	110	110.5	mm	
	Thickness (T)	5.5	6	6.5	mm	
Bezel Area	Horizontal	154.1	154.40	154.7	mm	
	Vertical	93.14	93.44	93.74	mm	
Active Area	Horizontal	-	152.4	-	mm	
	Vertical	-	91.44	-	mm	
Weight			(182.8)		g	

Note (1) Please refer to the attached drawings for more information of front and back outline dimensions.



2. ABSOLUTE MAXIMUM RATINGS

2.1 ABSOLUTE RATINGS OF ENVIRONMENT

Item	Symbol	Value		Unit	Note
		Min.	Max.		
Storage Temperature	Tst	-30	85	°C	(1), (2)
Operating Ambient Temperature	Top	-30	80	°C	

Note (1)

- (a) 90 %RH Max.
- (b) Wet-bulb temperature should be 39 °C Max.
- (c) No condensation.

Note (2) Panel surface temperature should be 0°C min. and 90°C max under Vcc=5.0V, fr =60Hz, typical LED string current, 25°C ambient temperature, and no humidity control . Any condition of ambient operating temperature ,the surface of active area should be keeping not higher than 85°C.

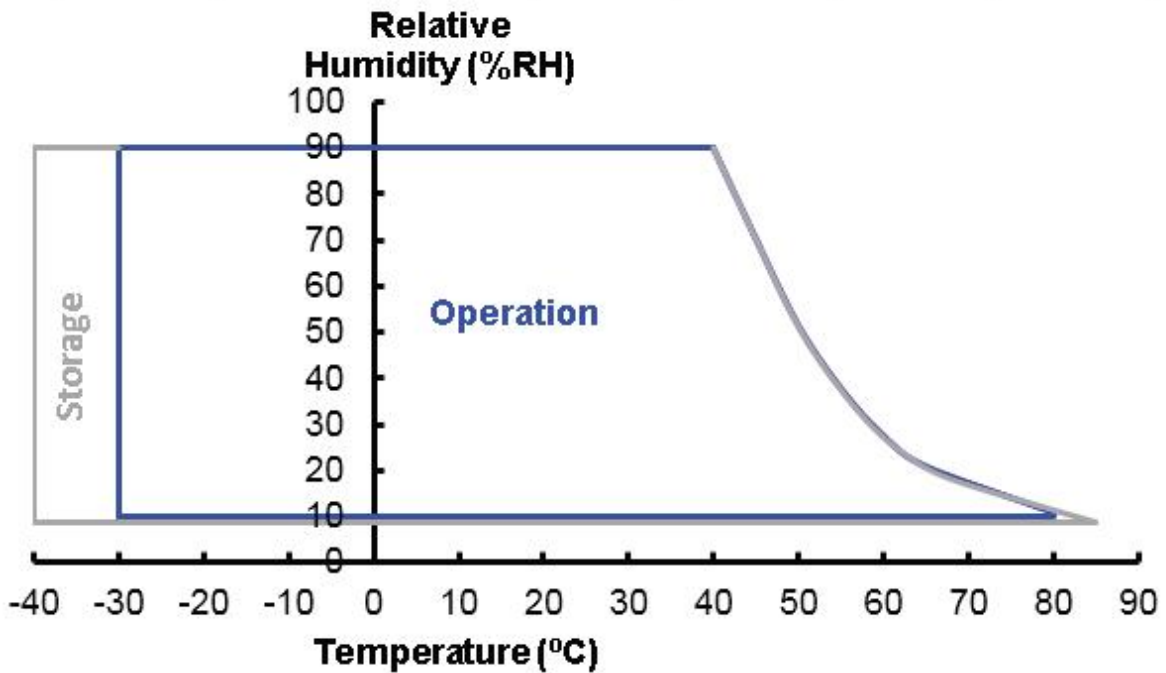



2.2 ELECTRICAL ABSOLUTE RATINGS

2.2.1 TFT LCD MODULE

Item	Symbol	Value		Unit	Note
		Min.	Max.		
Power Supply Voltage	V _{CC}	-0.3	3.6	V	(1)
Logic Input Voltage	V _{IN}	-0.3	3.6	V	

2.2.2 LED CONVERTER

Item	Symbol	Value			Unit	Note
		Min.	Typ	Max.		
Converter Voltage	LED_V _{in}	0	(12.0)	(18.0)	V	(1), (2)
Enable Voltage	LED_EN	0	3.3 / 5	7	V	Duty=100%
Backlight Adjust	LED_PWM	0	3.3 / 5	7	V	(1), (2) Pulse Width ≤ 10msec. and Duty ≤ 10%

Note (1) Permanent damage to the device may occur if maximum values are exceeded. Function operation should be restricted to the conditions described under Normal Operating Conditions.

Note (2) Specified values are for input pin of LED light bar at Ta=25±2 °C (Refer to 4.3.3 and 4.3.4 for further information)

3. ELECTRICAL CHARACTERISTICS

3.1 LCD ELETRONICS SPECIFICATION

Parameter	Symbol	Value			Unit	Note
		Min.	Typ.	Max.		
Power Supply Voltage	V _{CC}	3.0	3.3	3.6	V	-
Ripple Voltage	V _{RP}	-	-	100	mVp-p	-
Rush Current	I _{RUSH}	-	-	2	A	(2)
Power Supply Current	White	-	135	200	mA	(3)a
	Black	-	85	135	mA	(3)b
	Vertical Stripe	-	145	220	mA	(3)c
LVDS differential input voltage	V _{id}	200	-	600	mV	-
LVDS common input voltage	V _{ic}	1.0	1.2	1.4	V	-
Differential Input Voltage for LVDS Receiver Threshold	"H" Level	V _{TH}	-	+100	mV	-
	"L" Level	V _{TL}	-100	-	mV	-
Logic Input Voltage	"H" Level	V _{IH}	2.6	V _{CC}	V	-
	"L" Level	V _{IL}	0	0.7	V	-
Terminating Resistor	R _T	-	100	-	Ohm	-

Note (1) The ambient temperature is $T_a = 25 \pm 2$ °C. Note

(2) Measurement Conditions:

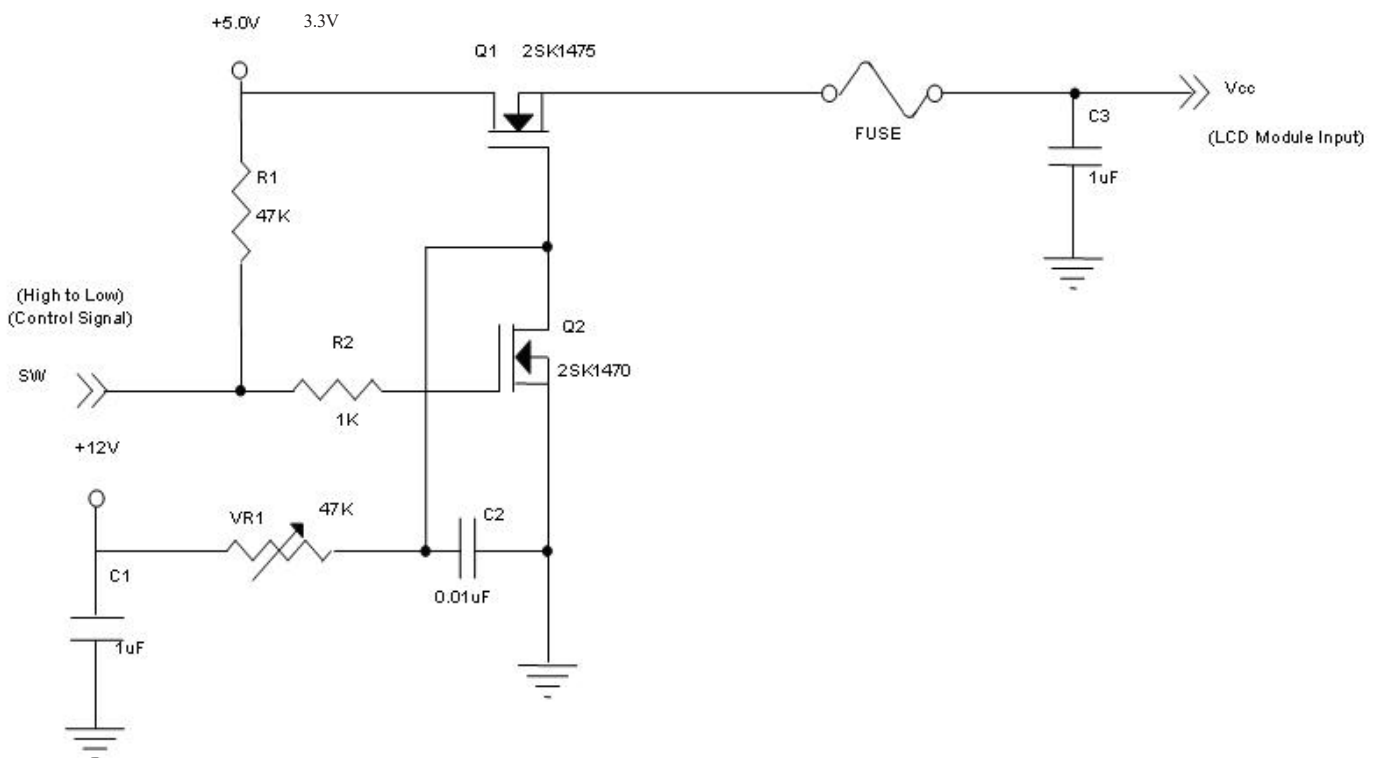

Vcc rising time is 470µs

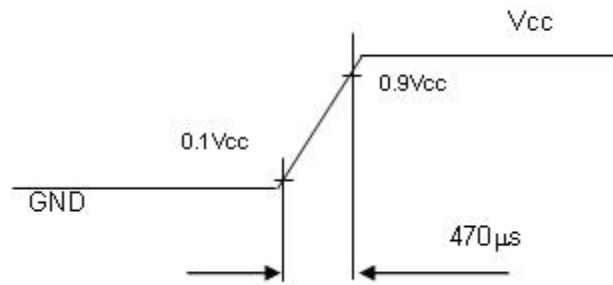

Note (3) The specified power supply current is under the conditions at Vcc = 3.3 V, Ta = 25 ± 2 °C, Fr = 60Hz, whereas a power dissipation check pattern below is displayed.

a. White Pattern

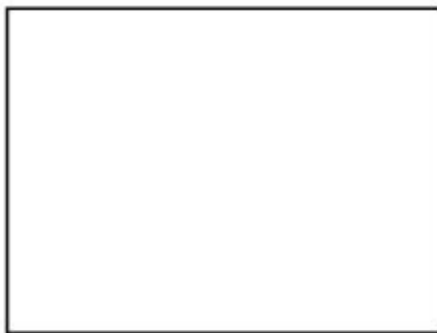

Active Area

b. Black Pattern



Active Area

c. Vertical Stripe Pattern

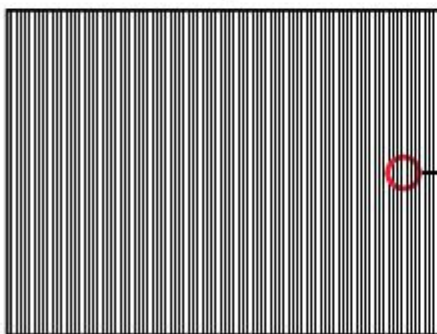

Active Area

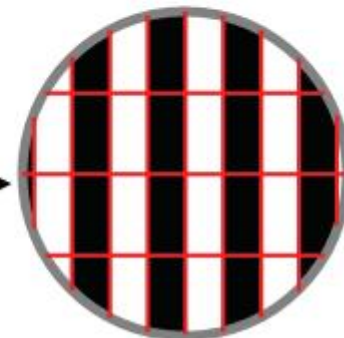

Note (4) The power consumption is specified at the pattern with the maximum current.

Note (5) VID waveform condition

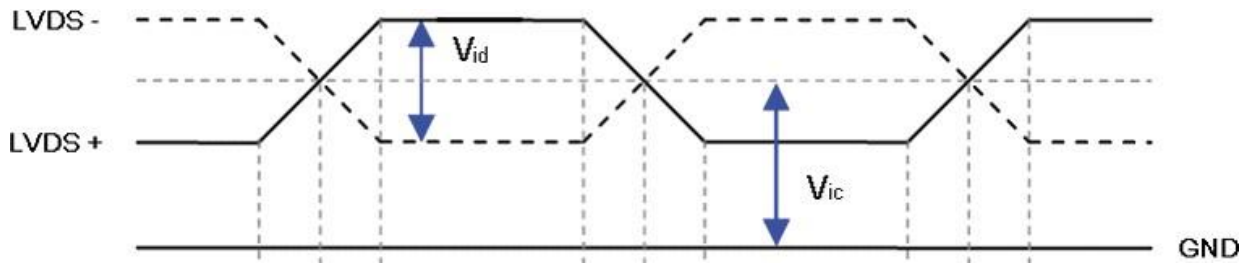

3.2 BACKLIGHT UNIT

Parameter	Symbol	Value			Unit	Note	
		Min.	Typ.	Max.			
(Converter input voltage)	V_i	10.8	12.0	13.2	V_{DC}	(Duty 100%)	
(Converter input ripple voltage)	V_{iRP}	-	-	500	mV		
(Converter input current)	I_i	0.2	0.3	0.4	A_{DC}	@ $V_i = 12V$ (Duty 100%)	
(Converter inrush current)	I_{iRUSH}	-	5		A	@ V_i rising time=10ms ($V_i=12V$)	
Input Power Consumption	P_i	-	3.5	4.0	W	(1)	
EN Control Level	Backlight on	ENLED (BLON)	2.5	3.3	5.0	V	
	Backlight off		0	---	0.3	V	
PWM Control Level	PWM High Level	Dimming (E_PWM)	2.5	---	5.0	V	
	PWM Low Level		0	---	0.15	V	
PWM Noise Range	V_{Noise}	-	-	0.1	V		
PWM Control Frequency	f_{PWM}	190	200	300	Hz	(3)	
PWM Control Duty Ratio	-	-	5		100	%	(3), @ 190Hz < f_{PWM} < 1kHz
			20		100	%	(3), @ 1kHz < f_{PWM} < 20kHz
LED Life Time	L_{LED}	50000	-	-	Hrs	(2)	

Note (1) LED current is measured by utilizing a high frequency current meter as shown below.

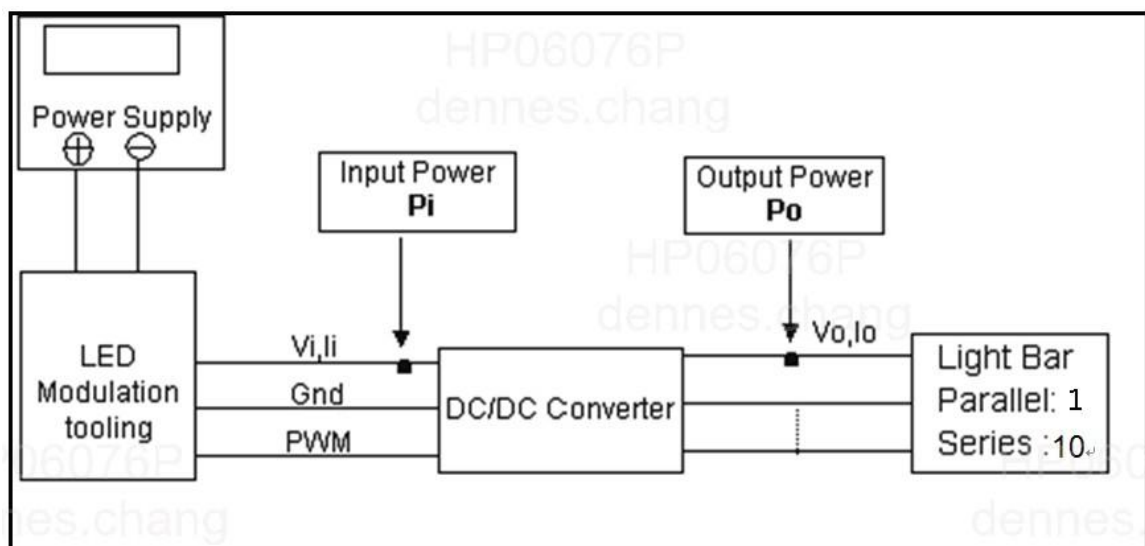

Note (2) The lifetime of LED is estimated data and defined as the time when it continues to operate under the conditions at $T_a = 25 \pm 2 \text{ }^\circ\text{C}$ and Duty 100% until the brightness becomes $\approx 50\%$ of its original value. Operating LED at high temperature condition will reduce life time and lead to color shift.

Note (3) At 190 ~1kHz PWM control frequency, duty ratio range is restricted from 5% to 100%.

1K ~20kHz PWM control frequency, duty ratio range is restricted from 20% to 100%.

If PWM control frequency is applied in the range from 1KHz to 20KHZ, The“non-linear”phenomenon on the Backlight Unit may be found. So It's a suggestion that PWM control frequency should be less than 1KHz.

4. ELECTRICAL SPECIFICATIONS

4.1 TFT LCD MODULE

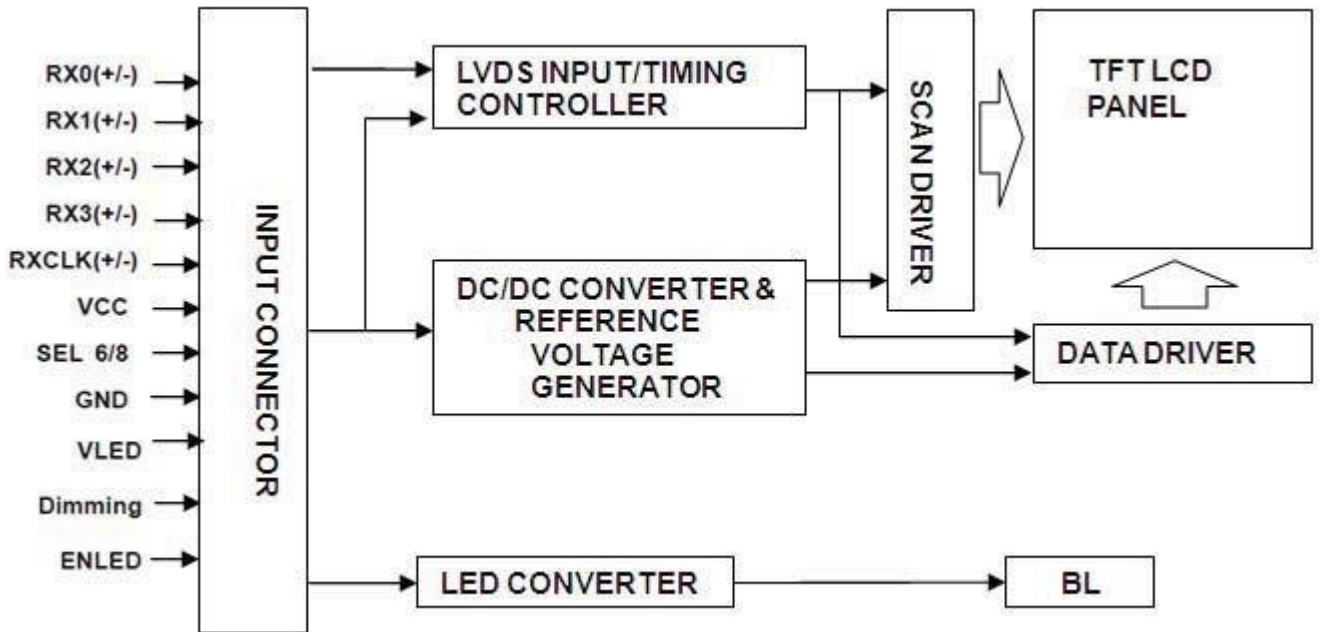



5. INTERFACE CONNECTIONS

5.1 TFT LCD MODULE

Pin No.	Symbol	Description	Note
1	12V	LED power	-
2	12V	LED power	-
3	12V	LED power	-
4	12V	LED power	-
5	ENLED	Enable pin	-
6	Dimming	Backlight Adjust	-
7	NC	No Connction (Reserve for INX test)	(3)
8	NC	No Connction (Reserve for INX test)	(3)
9	VCC	Power supply: +3.3V	-
10	VCC	Power supply: +3.3V	-
11	GND	Ground	-
12	GND	Ground	-
13	RX0-	Negative transmission data of pixel 0	-
14	RX0+	Positive transmission data of pixel 0	-
15	GND	Ground	-
16	RX1-	Negative transmission data of pixel 1	-
17	RX1+	Positive transmission data of pixel 1	-
18	GND	Ground	-
19	RX2-	Negative transmission data of pixel 2	-
20	RX2+	Positive transmission data of pixel 2	-
21	GND	Ground	-
22	RXCLK-	Negative of clock	-
23	RXCLK+	Positive of clock	-
24	GND	Ground	-
25	RX3-	Negative transmission data of pixel 3	-
26	RX3+	Positive transmission data of pixel 3	-
27	GND	Ground	-
28	SEL6/8	LVDS 6/8 bit select function control,	(2)
		Low → 6 bit Input Mode	
		High or NC → 8bit Input Mode	
29	GND	Ground	-
30	GND	Ground	-

Note (1) Connector Part No.: Starconn 093G30-B0001A-G4.

Note (2) “Low” stands for 0V. “High” stands for 3.3V

Note (3) Pin7, Pin8 input signals should be set to no connection or ground, this module would operate normally.

SEL6/8 pin:

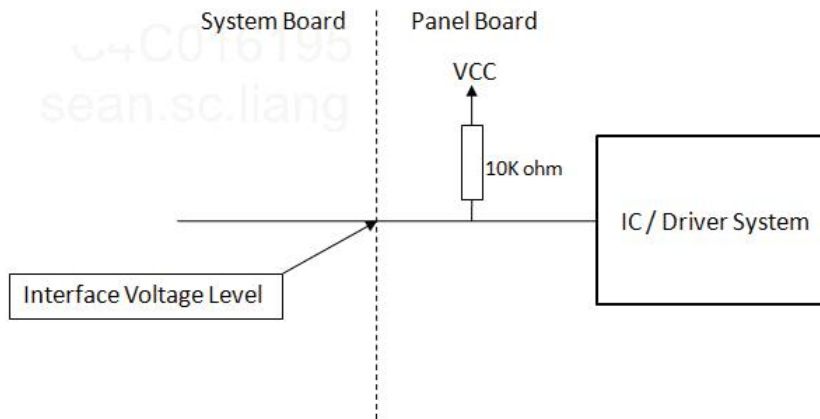

5.2. COLOR DATA INPUT ASSIGNMENT

The brightness of each primary color (red, green and blue) is based on the 8-bit gray scale data input for the color. The higher the binary input, the brighter the color. The table below provides the assignment of color.

Color		Data Signal																							
		Red								Green								Blue							
		R7	R6	R5	R4	R3	R2	R1	R0	G7	G6	G5	G4	G3	G2	G1	G0	B7	B6	B5	B4	B3	B2	B1	B0
Basic Colors	Black	0	0	0	0	0	0	0	0	0	0	0	0	0	0	0	0	0	0	0	0	0	0	0	
	Red	1	1	1	1	1	1	1	1	0	0	0	0	0	0	0	0	0	0	0	0	0	0	0	
	Green	0	0	0	0	0	0	0	0	1	1	1	1	1	1	1	1	0	0	0	0	0	0	0	
	Blue	0	0	0	0	0	0	0	0	0	0	0	0	0	0	0	0	1	1	1	1	1	1	1	
	Cyan	0	0	0	0	0	0	0	0	1	1	1	1	1	1	1	1	1	1	1	1	1	1	1	
	Magenta	1	1	1	1	1	1	1	1	0	0	0	0	0	0	0	0	1	1	1	1	1	1	1	
	Yellow	1	1	1	1	1	1	1	1	1	1	1	1	1	1	1	1	0	0	0	0	0	0	0	
	White	1	1	1	1	1	1	1	1	1	1	1	1	1	1	1	1	1	1	1	1	1	1	1	
Gray Scale Of Red	Red(0) / Dark	0	0	0	0	0	0	0	0	0	0	0	0	0	0	0	0	0	0	0	0	0	0		
	Red(1)	0	0	0	0	0	0	0	1	0	0	0	0	0	0	0	0	0	0	0	0	0	0		
	Red(2)	0	0	0	0	0	0	1	0	0	0	0	0	0	0	0	0	0	0	0	0	0	0		
	⋮	⋮	⋮	⋮	⋮	⋮	⋮	⋮	⋮	⋮	⋮	⋮	⋮	⋮	⋮	⋮	⋮	⋮	⋮	⋮	⋮	⋮			
	⋮	⋮	⋮	⋮	⋮	⋮	⋮	⋮	⋮	⋮	⋮	⋮	⋮	⋮	⋮	⋮	⋮	⋮	⋮	⋮	⋮	⋮			
	⋮	⋮	⋮	⋮	⋮	⋮	⋮	⋮	⋮	⋮	⋮	⋮	⋮	⋮	⋮	⋮	⋮	⋮	⋮	⋮	⋮	⋮			
	Red(253)	1	1	1	1	1	1	0	1	0	0	0	0	0	0	0	0	0	0	0	0	0	0		
	Red(254)	1	1	1	1	1	1	1	0	0	0	0	0	0	0	0	0	0	0	0	0	0	0		
Red(255)	1	1	1	1	1	1	1	1	0	0	0	0	0	0	0	0	0	0	0	0	0	0			
Gray Scale Of Green	Green(0)/Dark	0	0	0	0	0	0	0	0	0	0	0	0	0	0	0	0	0	0	0	0	0	0		
	Green(1)	0	0	0	0	0	0	0	0	0	0	0	0	0	0	1	0	0	0	0	0	0	0		
	Green(2)	0	0	0	0	0	0	0	0	0	0	0	0	0	1	0	0	0	0	0	0	0	0		
	⋮	⋮	⋮	⋮	⋮	⋮	⋮	⋮	⋮	⋮	⋮	⋮	⋮	⋮	⋮	⋮	⋮	⋮	⋮	⋮	⋮	⋮			
	⋮	⋮	⋮	⋮	⋮	⋮	⋮	⋮	⋮	⋮	⋮	⋮	⋮	⋮	⋮	⋮	⋮	⋮	⋮	⋮	⋮	⋮			
	Green(253)	0	0	0	0	0	0	0	0	1	1	1	1	1	1	0	1	0	0	0	0	0	0		
	Green(254)	0	0	0	0	0	0	0	0	1	1	1	1	1	1	1	0	0	0	0	0	0	0		
	Green(255)	0	0	0	0	0	0	0	0	1	1	1	1	1	1	1	1	0	0	0	0	0	0		
Gray Scale Of Blue	Blue(0) / Dark	0	0	0	0	0	0	0	0	0	0	0	0	0	0	0	0	0	0	0	0	0	0		
	Blue(1)	0	0	0	0	0	0	0	0	0	0	0	0	0	0	0	0	0	0	0	0	0	1		
	Blue(2)	0	0	0	0	0	0	0	0	0	0	0	0	0	0	0	0	0	0	0	0	0	1		
	⋮	⋮	⋮	⋮	⋮	⋮	⋮	⋮	⋮	⋮	⋮	⋮	⋮	⋮	⋮	⋮	⋮	⋮	⋮	⋮	⋮	⋮			
	⋮	⋮	⋮	⋮	⋮	⋮	⋮	⋮	⋮	⋮	⋮	⋮	⋮	⋮	⋮	⋮	⋮	⋮	⋮	⋮	⋮	⋮			
	Blue(253)	0	0	0	0	0	0	0	0	0	0	0	0	0	0	0	1	1	1	1	1	1	0		
	Blue(254)	0	0	0	0	0	0	0	0	0	0	0	0	0	0	0	1	1	1	1	1	1	1		
	Blue(255)	0	0	0	0	0	0	0	0	0	0	0	0	0	0	0	1	1	1	1	1	1	1		

Note (1) 0: Low Level Voltage, 1: High Level Voltage

6. INTERFACE TIMING

6.1 INPUT SIGNAL TIMING SPECIFICATIONS

The input signal timing specifications are shown as the following table and timing diagram.

Signal	Item	Symbol	Min.	Typ.	Max.	Unit	Note
LVDS Clock	Frequency	F _c	25.2	25.4	35.7	MHz	-
	Period	T _c		39.37		ns	
	Input cycle to cycle jitter	T _{rcd}	-0.02*T _c	-	0.02*T _c	ns	(3)
	Input clock to data skew	TLVCCS	-0.02*T _c	-	0.02*T _c	ns	(4)
	Spread spectrum modulation range	F _{clkin_mod}	FC*98%	-	FC*102%	MHz	(5)
	Spread spectrum modulation frequency	F _{SSM}	23	-	93	KHz	
Vertical Display Term	Frame Rate	Fr	-	60	-	Hz	T _v =T _{vd} +T _{vb}
	Total	T _v	488	490	611	Th	-
	Active Display	T _{vd}	480	480	480	Th	-
	Blank	T _{vb}	8	10	131	Th	-
Horizontal Display Term	Total	T _h	860	864	974	T _c	T _h =T _{hd} +T _{hb}
	Active Display	T _{hd}	800	800	800	T _c	-
	Blank	T _{hb}	60	64	174	T _c	-

Note (1) Because this module is operated by DE only mode, Hsync and Vsync input signals are ignored.

Note (2) The T_v(T_{vd}+T_{vb}) must be integer, otherwise, this module would operate abnormally.

INPUT SIGNAL TIMING DIAGRAM

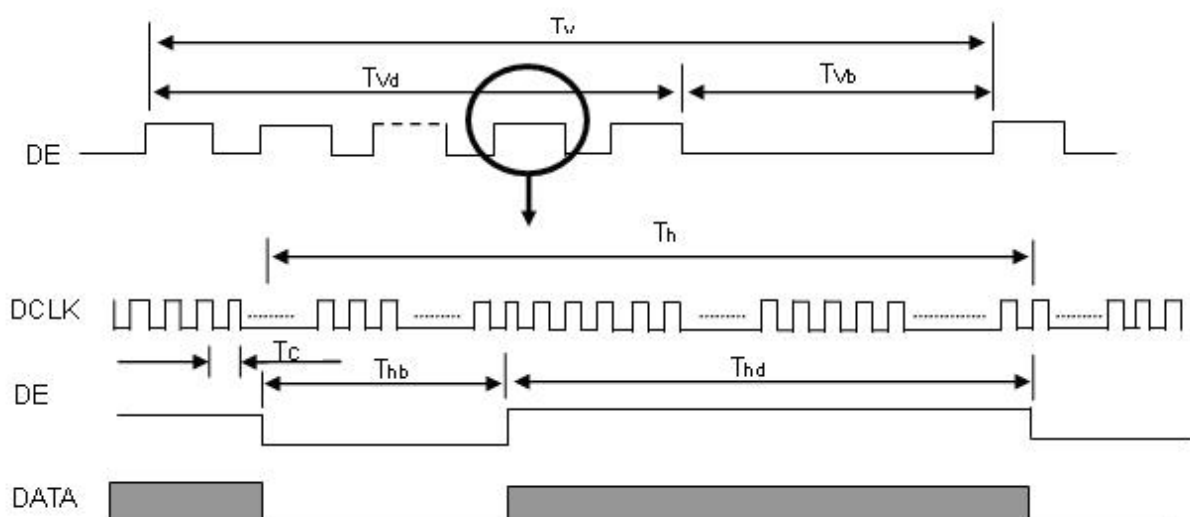

Note (3) The input clock cycle-to-cycle jitter is defined as below figures. $Trcl = |T_1 - T_1|$

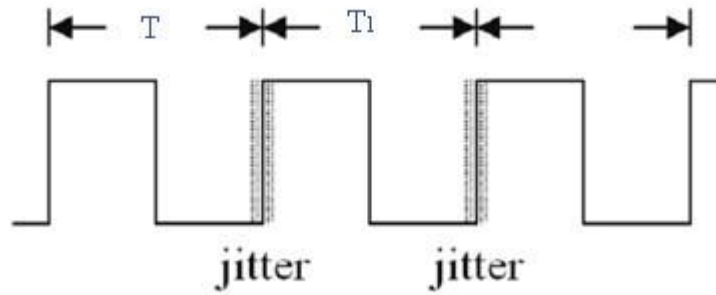

Note (4) Input Clock to data skew is defined as below figures.

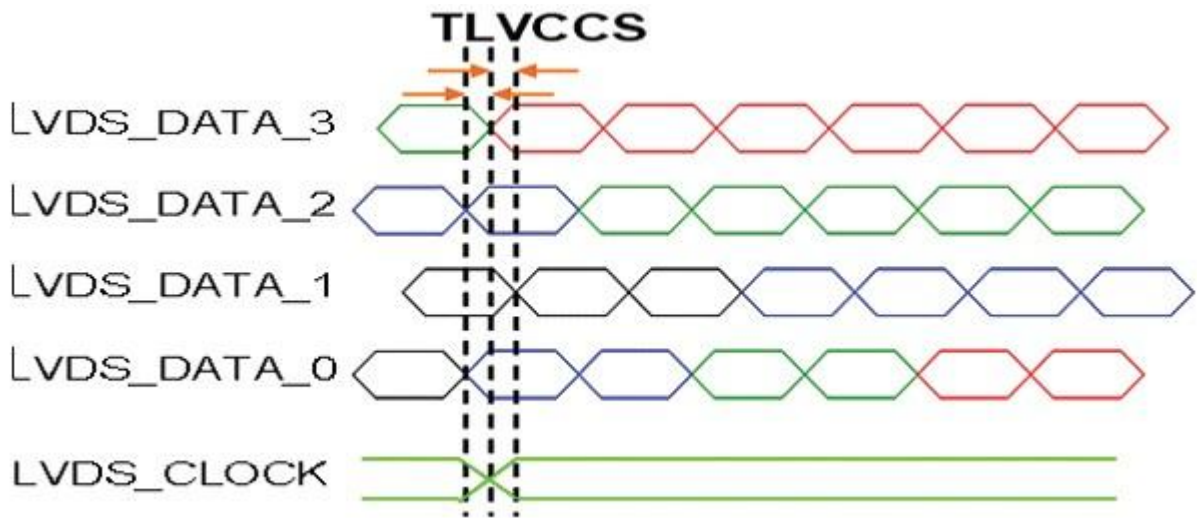

Note (5) The SSCG (Spread spectrum clock generator) is defined as below figures.

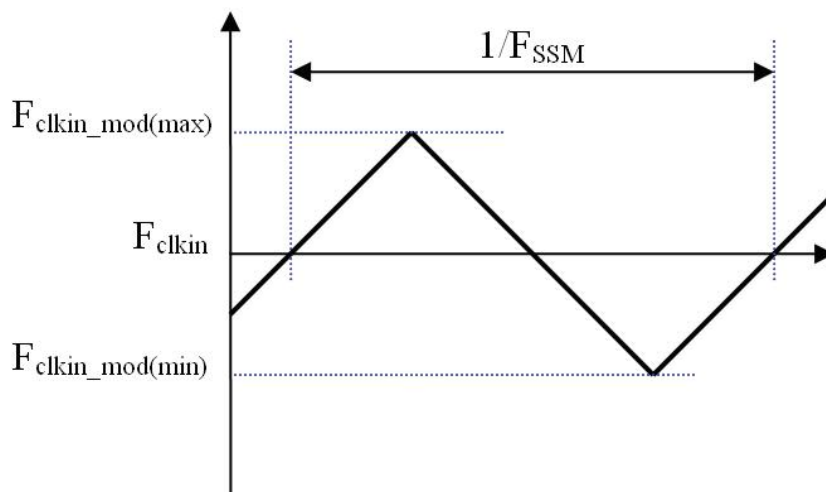

6.2 POWER ON/OFF SEQUENCE

The power sequence specifications are shown as the following table and diagram.

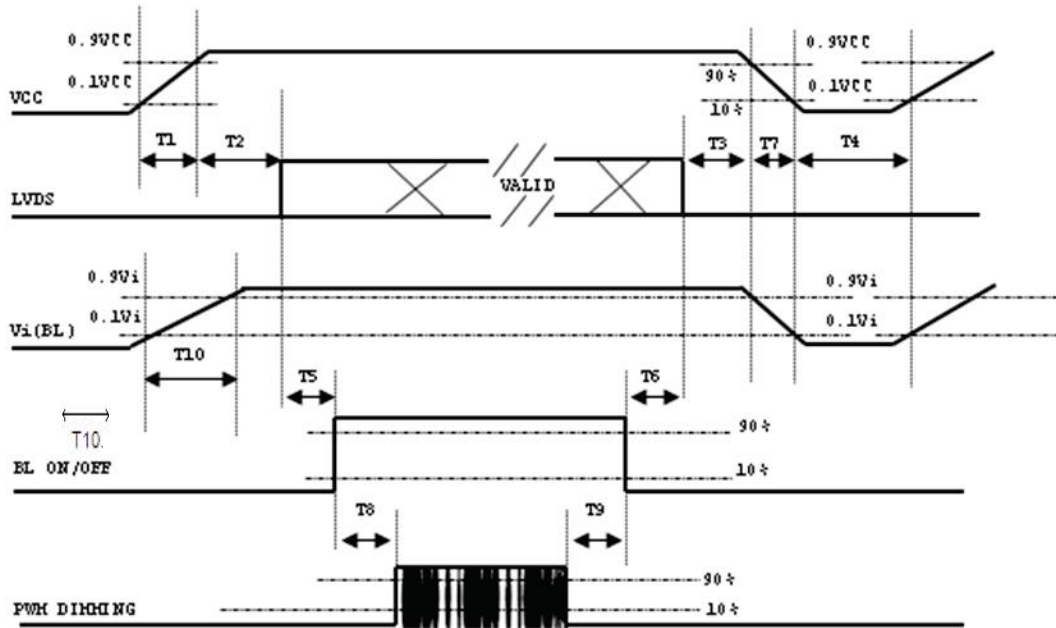

Timing Specifications:

Parameter	Value			Units
	Min	Typ	Max	
T1	0.5	-	10	ms
T2	0	-	50	ms
T3	0	-	50	ms
T4	500	-	-	ms
T5	450	-	-	ms
T6	200	-	-	ms
T7	10	-	100	ms
T8	10	-	-	ms
T9	10	-	-	ms
T10	20	-	50	ms

- (1) The supply voltage of the external system for the module input should be the same as the definition of Vcc.
- (2) When the backlight turns on before the LCD operation of the LCD turns off, the display may momentarily become abnormal screen.
- (3) In case of VCC = off level, please keep the level of input signals on the low or keep a high impedance.
- (4) T4 should be measured after the module has been fully discharged between power off and on period.

- (5) Interface signal shall not be kept at high impedance when the power is on.
- (6) INX won't take any responsibility for the products which are damaged by the customers not following the Power Sequence.
- (7) There might be slight electronic noise when LCD is turned off (even backlight unit is also off). To avoid this symptom, we suggest "Vcc falling timing" to follow "T7 spec"

6.3 The Input Data Format

SEL 6/8="Low" for 6 Bits LVDS

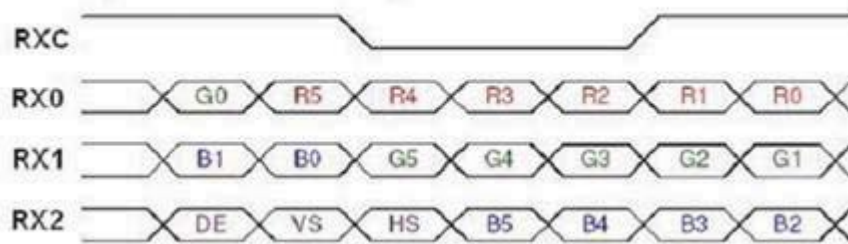

SEL 6/8="High" for 8 Bits LVDS



Note (1) R/G/B data 7: MSB, R/G/B data 0: LSB

Note (2) Please follow PSWG



PRODUCT SPECIFICATION

Signal Name	Description	Remark
R7 R6 R5 R4 R3 R2 R1 R0	Red Data 7 (MSB) Red Data 6 Red Data 5 Red Data 4 Red Data 3 Red Data 2 Red Data 1 Red Data 0 (LSB)	Red-pixel Data Each red pixel's brightness data consists of these 8 bits pixel data.
G7 G6 G5 G4 G3 G2 G1 G0	Green Data 7 (MSB) GreenData 6 GreenData 5 GreenData 4 GreenData 3 GreenData 2 GreenData 1 GreenData 0 (LSB)	Green-pixel Data Each green pixel's brightness data consists of these 8 bits pixel data.
B7 B6 B5 B4 B3 B2 B1 B0	Blue Data 7 (MSB) Blue Data 6 Blue Data 5 Blue Data 4 Blue Data 3 Blue Data 2 Blue Data 1 Blue Data 0 (LSB)	Blue-pixel Data Each blue pixel's brightness data consists of these 8 bits pixel data.
RXCLKIN+ RXCLKIN-	LVDS Clock Input	
DE	Display Enable	
VS	Vertical Sync	
HS	Horizontal Sync	



6.4 Scanning Direction

The following figures show the image see from the front view. The arrow indicates the direction of scan.

Fig.1 Normal Scan



PCBA on the bottom side

7. OPTICAL CHARACTERISTICS

7.1 TEST CONDITIONS

Item	Symbol	Value	Unit
Ambient Temperature	Ta	25±2	oC
Ambient Humidity	Ha	50±10	%RH
Supply Voltage	According to typical value and tolerance in "ELECTRICAL CHARACTERISTICS"		
Input Signal			
PWM Duty Ratio	D	100	%

7.2 OPTICAL SPECIFICATIONS

The relative measurement methods of optical characteristics are shown here and all items are measured at the center point of screen unless otherwise noted. The following items should be measured under the test conditions described above and stable conditions shown in Note (5).

Item	Symbol	Condition	Min.	Typ.	Max.	Unit	Note			
Color Chromaticity (CIE 1931)	Red	Rx	0.534	0.584	0.634	-	(1), (5)			
		Ry	0.280	0.330	0.380					
	Green	Gx	0.284	0.334	0.384					
		Gy	0.550	0.600	0.650					
	Blue	Bx	0.100	0.150	0.200					
		By	0.004	0.054	0.104					
	White	Wx	0.263	0.313	0.363					
		Wy	0.279	0.329	0.379					
	Center Luminance of White	Lc		800	1000			-	nits	(4), (5)
	Contrast Ratio	CR		600	800			-	-	(2), (5)
Response Time	TR	$\theta_x=0^\circ, \theta_y=0^\circ$	-	13	-	ms	(3)			
	TF		-	12	-					
White Variation	W	$\theta_x=0^\circ, \theta_y=0^\circ$	70	-	-	%	(5), (6)			
Viewing Angle	Horizontal	θ_{x+}	80	89	---	Deg.	(1), (5)			
		θ_{x-}	80	89						
	Vertical	θ_{y+}	80	89						
		θ_{y-}	80	89	---					

Definition 燙

Grayscale Maximum : Grayscale 255 (10 bits: grayscale 1023 ; 8 bits : grayscale 255 ; 6 bits: grayscale 63)

White : Luminance of Grayscale Maximum (All R,G,B)

Black : Luminance of grayscale 0 (All R,G,B)

Note (1) Definition of Viewing Angle (θ_x, θ_y):

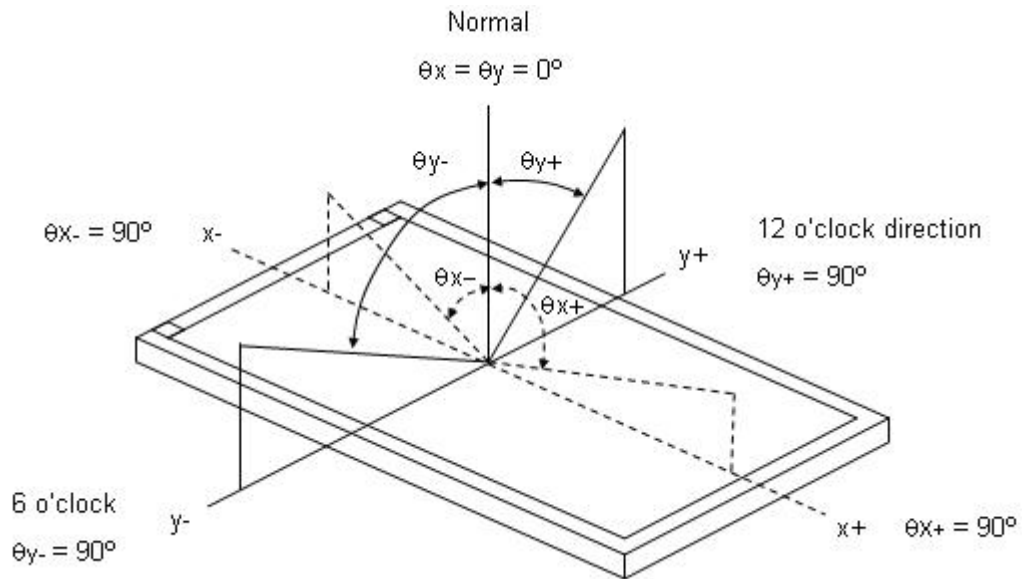

Note (2) Definition of Contrast Ratio (CR):

The contrast ratio can be calculated by the following expression at center point.

$$\text{Contrast Ratio (CR)} = \text{White} / \text{Black}$$

Note (3) Definition of Response Time (T_R, T_F):

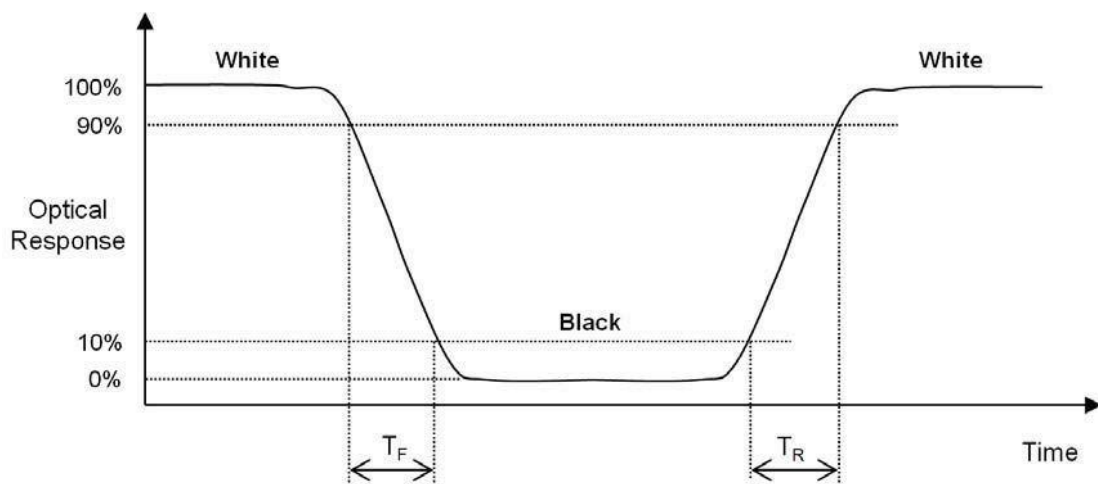

Note (4) Definition of Luminance of White (LC):

Measure the luminance of White at center point

Note (5) Measurement Setup:

The LCD module should be stabilized at given temperature to avoid abrupt temperature change during measuring. In order to stabilize the luminance, the measurement should be executed after lighting Backlight for 40 minutes in a windless room. The measurement placement of module should be in accordance with module drawing.

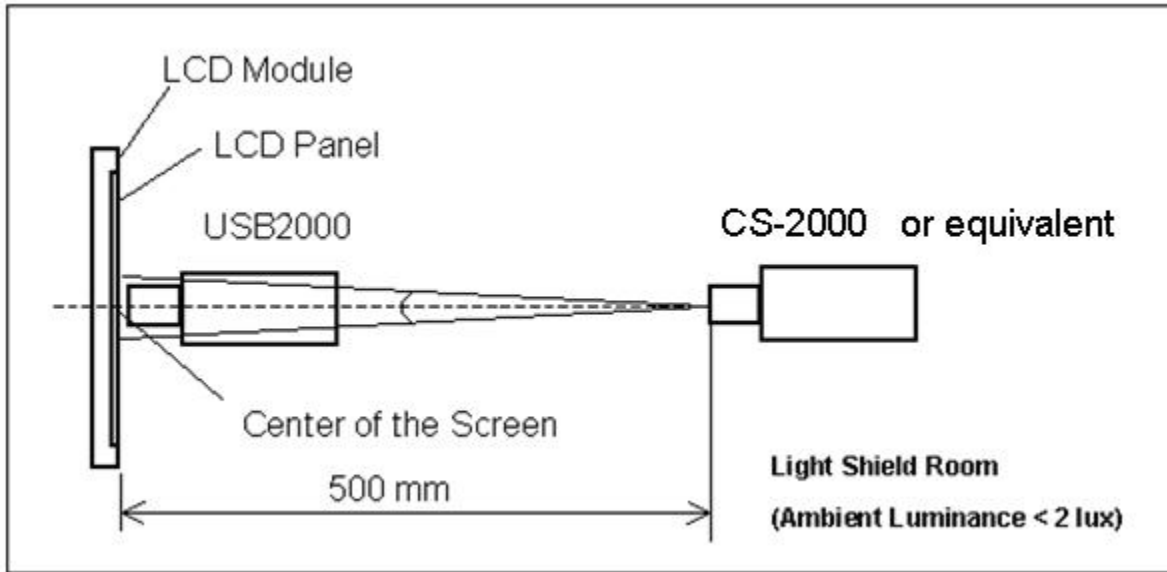

Note (6) Definition of White Variation (δW):

Measure the luminance of White at 5 points.

Luminance of White : $L(X)$, where X is from 1 to 5.

$$\delta W = \frac{\text{Minimum [} L(1) \text{ to } L(5) \text{]}}{\text{Maximum [} L(1) \text{ to } L(5) \text{]}} \times 100\%$$

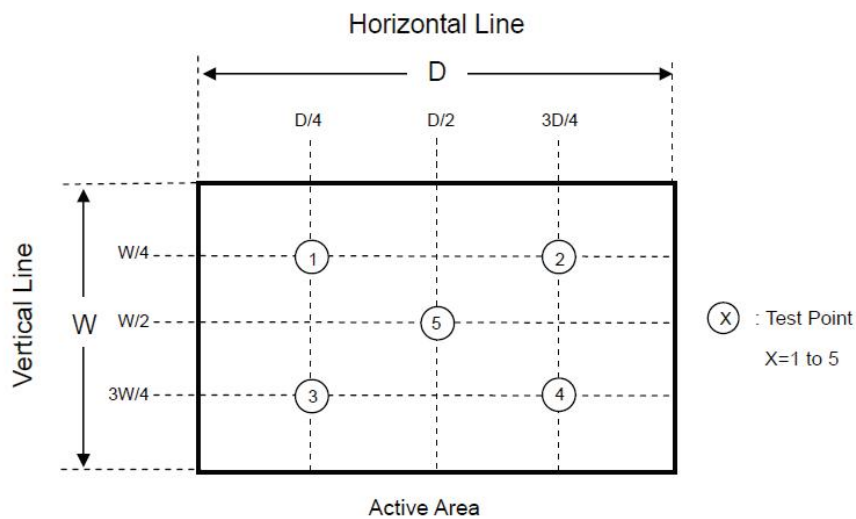



8. RELIABILITY TEST ITEM

Test Item	Test Condition	Note
High Temperature Storage Test	85°C, 240 hours	(1),(2) (4),(5)
Low Temperature Storage Test	-30°C, 240 hours	
Thermal Shock Storage Test	-30°C, 0.5hour → 80°C, 0.5hour; 100cycles, 1hour/cycle	
High Temperature Operation Test	80°C, 240 hours	
Low Temperature Operation Test	-30°C, 240 hours	
High Temperature & High Humidity Operation Test	60°C, 90%RH, 240hours	(1),(4)
ESD Test (Operation)	150pF, 330Ω , 1 sec/cycle Condition 1 : panel contact, U8 KV Condition 2 : panel non-contact U15 KV	
Shock (Non-Operating)	50G, 11ms, half sine wave, 1 time for ± X, ± Y, ± Z direction	(2),(3)
Vibration (Non-Operating)	1.5G, 10 ~ 300 Hz sine wave, 10 min/cycle, 3 cycles each X, Y, Z direction	

Note (1) There should be no condensation on the surface of panel during test ,

Note (2) Temperature of panel display surface area should be 85°C Max.

Note (3) At testing Vibration and Shock, the fixture in holding the module has to be hard and rigid enough so that the module would not be twisted or bent by the fixture.

Note (4) In the standard conditions, there is no function failure issue occurred. All the cosmetic specification is judged before reliability test.

Note (5) Before cosmetic and function test, the product must have enough recovery time, at least 2] hours at room temperature.

9. PACKING

9.1 PACKING SPECIFICATIONS

- (1) 38 pcs LCD modules / 1 Box
- (2) Box dimensions: 445 (L) X 370 (W) X 275 (H) mm
- (3) Weight: approximately 8.3Kg (38modules per box)

9.2 PACKING METHOD

LCD Module

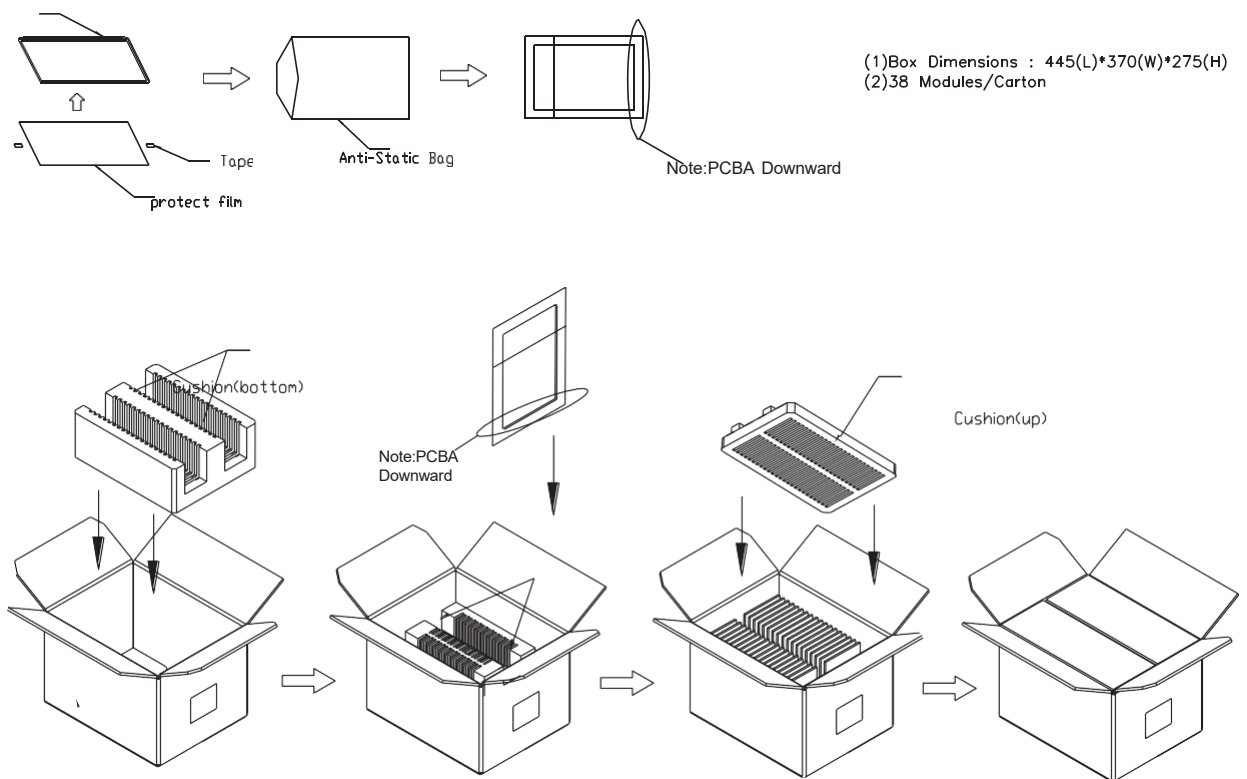

Figure. 9-1 Packing method

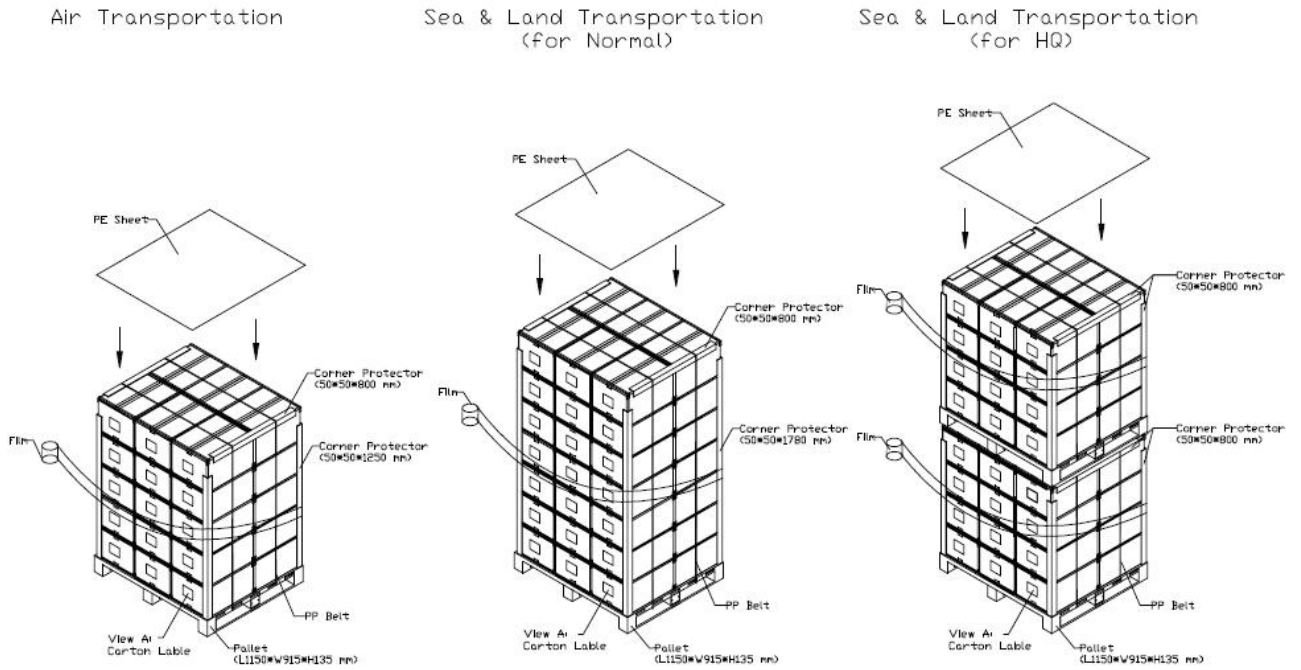

Figure. 9-2 Packing method

9.3 UN-PACKING METHOD

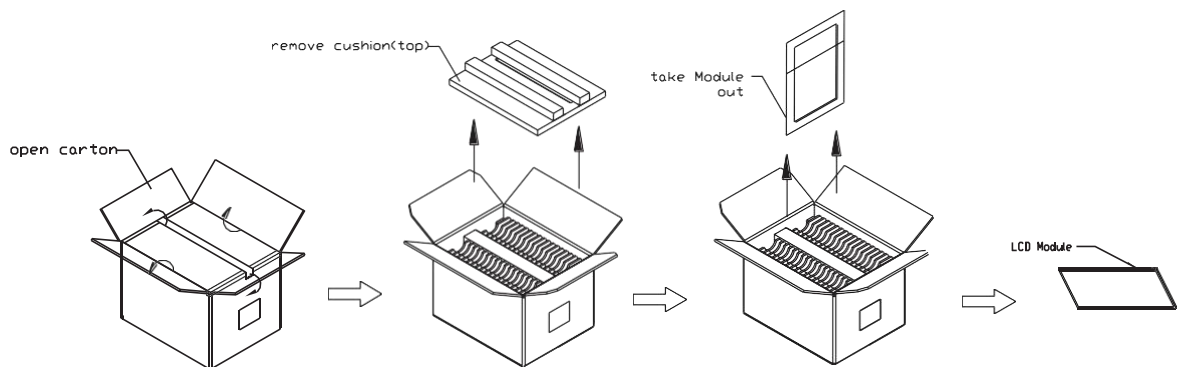

Figure. 7-3 UN-Packing method



10. MODULE LABEL

10.1 INX MODULE LABEL

The barcode nameplate is pasted on each module as illustration, and its definitions are as following explanation.

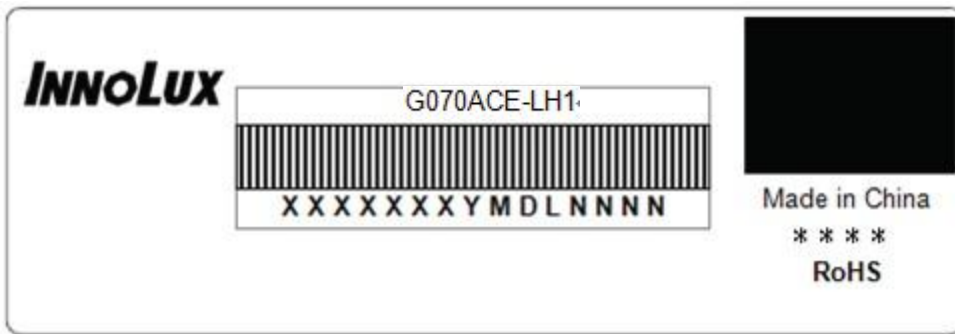

- (a) Model Name: G070ACE-LH1
- (b) Revision: Rev. XX, for example: A1, B1, C1, C2 ...etc.
- (c) 焮焮焮焮: Factory ID
- (d) Serial ID: X X X X X X Y M D X N N N N

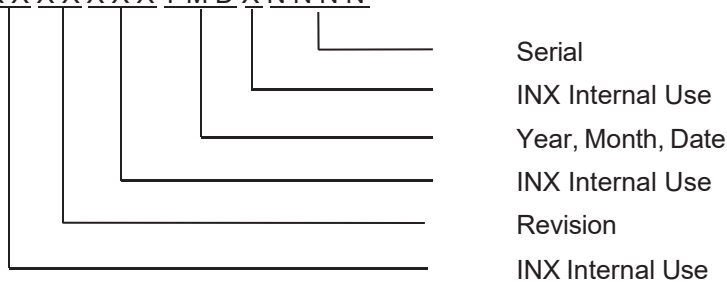

Serial ID includes the information as below:

- (a) Manufactured Date: Year: 1~9, for 2011~2019
 Month: 1~9, A~C, for Jan. ~ Dec.
 Day: 1~9, A~Y, for 1st to 31st, exclude I , O and U
- (b) Revision Code: cover all the change
- (c) Serial No.: Manufacturing sequence of product

11. PRECAUTIONS

11.1 ASSEMBLY AND HANDLING PRECAUTIONS

- (1) The module should be assembled into the system firmly by using every mounting hole. Be careful not to twist or bend the module.
- (2) While assembling or installing modules, it can only be in the clean area. The dust and oil may cause electrical short or damage the polarizer.
- (3) Use fingerstalls or soft gloves in order to keep display clean during the incoming inspection and assembly process.
- (4) Do not press or scratch the surface harder than a HB pencil lead on the panel because the polarizer is very soft and easily scratched.
- (5) If the surface of the polarizer is dirty, please clean it by some absorbent cotton or soft cloth. Do not use Ketone type materials (ex. Acetone), Ethyl alcohol, Toluene, Ethyl acid or Methyl chloride. It might permanently damage the polarizer due to chemical reaction.
- (6) Wipe off water droplets or oil immediately. Staining and discoloration may occur if they left on panel for a long time.
- (7) If the liquid crystal material leaks from the panel, it should be kept away from the eyes or mouth. In case of contacting with hands, legs or clothes, it must be washed away thoroughly with soap.
- (8) Protect the module from static electricity, it may cause damage to the C-MOS Gate Array IC.
- (9) Do not disassemble the module.
- (10) Do not pull or fold the lamp wire.
- (11) Pins of I/F connector should not be touched directly with bare hands.

11.2 STORAGE PRECAUTIONS

- (1) When storing for a long time, the following precautions are necessary.
 - (a) Store them in a dark place. Do not expose the module to sunlight or fluorescent light. Keep the temperature between 5°C and 30°C at humidity 50+-10%RH.
 - (b) The polarizer surface should not come in contact with any other object.
 - (c) It is recommended that they be stored in the container in which they were shipped.
 - (d) Storage condition is guaranteed under packing conditions.
 - (e) The phase transition of Liquid Crystal in the condition of the low or high storage temperature will be recovered when the LCD module returns to the normal condition
- (2) High temperature or humidity may reduce the performance of module. Please store LCD module within the specified storage conditions.
- (3) It is dangerous that moisture come into or contacted the LCD module, because the moisture may damage LCD module when it is operating.
- (4) It may reduce the display quality if the ambient temperature is lower than 10 °C. For example, the response time will become slowly, and the starting voltage of lamp will be higher than the room temperature.



11.3 OTHER PRECAUTIONS

- (1) Normal operating condition
 - (a) Display pattern: dynamic pattern (Real display)
(Note) Long-term static display can cause image sticking.
- (2) Operating usages to protect against image sticking due to long-term static display
 - (a) Suitable operating time: under 16 hours a day.
 - (b) Static information display recommended to use with moving image.
 - (c) Cycling display between 5 minutes' information(static) display and 10 seconds' moving image.
- (3) Abnormal condition just means conditions except normal condition.

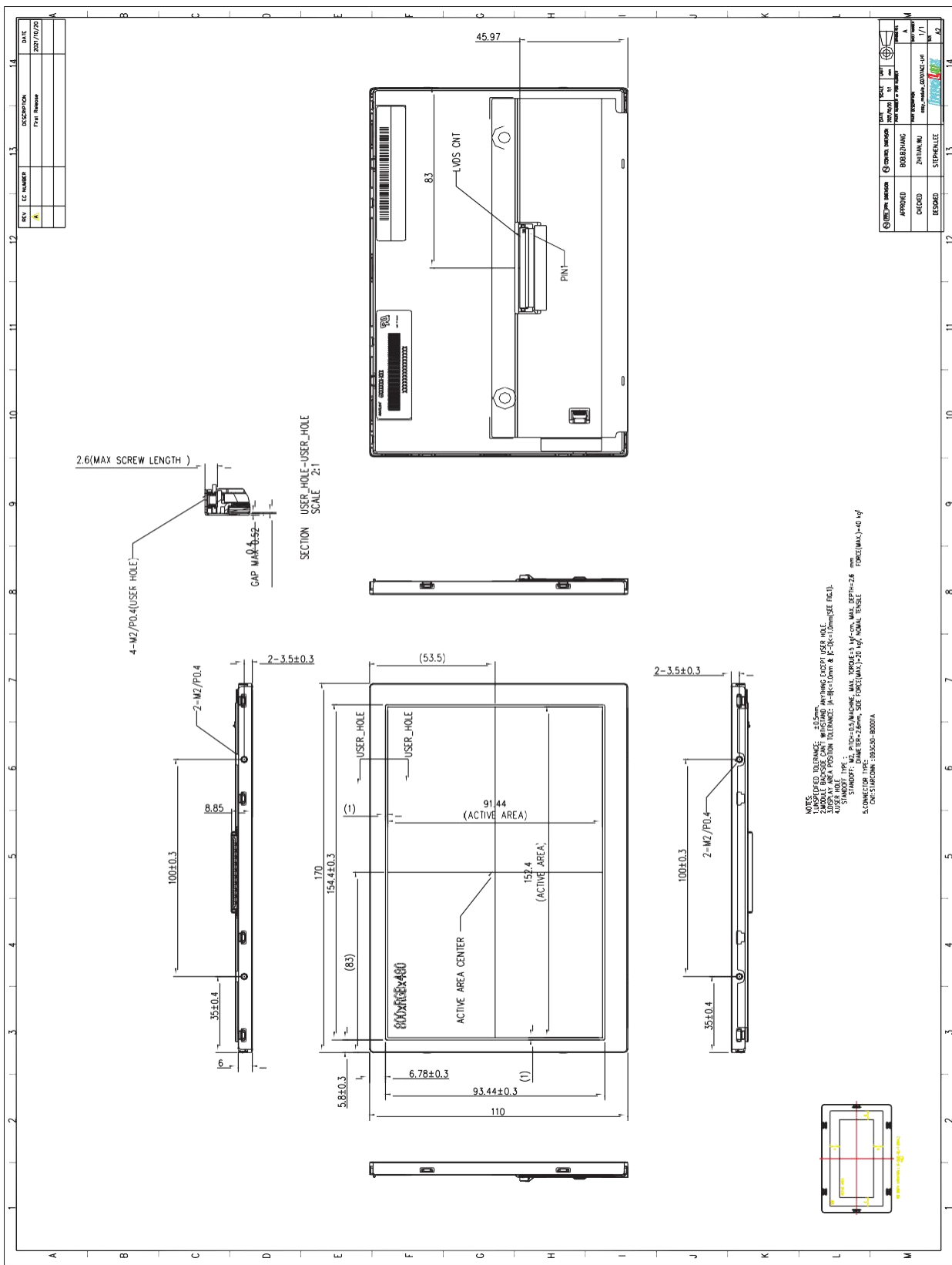
12. MECHANICAL CHARACTERISTIC

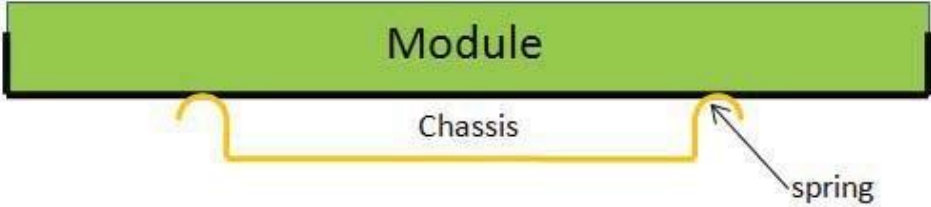
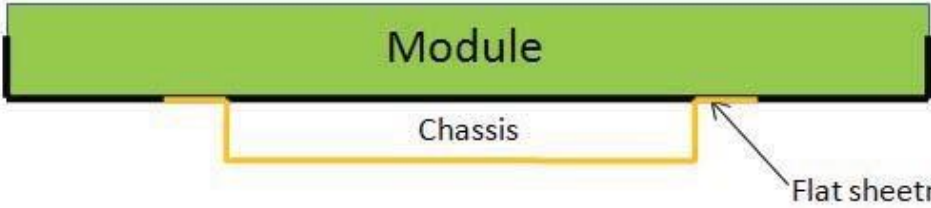
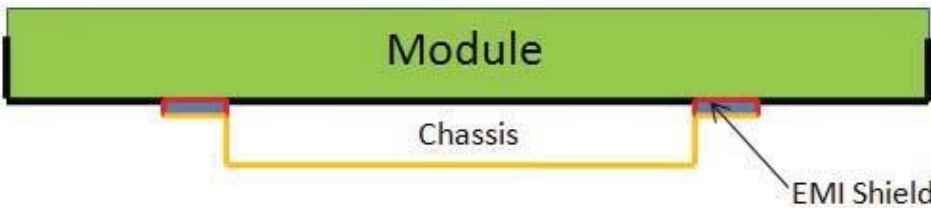

Appendix . SYSTEM COVER DESIGN NOTICE

1	Set Chassis and IAVM Module touching Mode
  	  
Definition	<p>a. To prevent from abnormal display & white spot after mechanical test, it is not recommended to use spring type chassis.</p> <p>b. We suggest the contact mode between Chassis and Module rear cover is Tape/Sponge, second is Flat sheet metal type chassis.</p>

2	Tape/Sponge design on system inner surface
Definition	<p>a. To prevent from abnormal display & white spot after mechanical test, we suggest using Tape/Sponge as medium between chassis and Module rear cover could reduce the occurrence of white spot.</p> <p>b. When using the Tape/Sponge, we suggest it be lay over between set chassis and Module rear cover. It is not recommended to add Tape/Sponge in separate location. Since each Tape/Sponge may act as pressure concentration location.</p>

3	System inner surface examination
Definition	<p>a. The hatch area on Module PCBA should keep at least 1mm gap(X,Y,Z direction) to any structure with system cover inner surface.</p> <p>b. Burr, Step, PCB protrusion may cause stress concentration. White spot may occur during reliability test.</p>

4	Material used for system rear-cover
Definition	<p>System rear-cover material with high rigidity is needed to resist deformation during scuffing test, hinge test, pogo test or backpack test. Abnormal display, white spot, pooling issue may occur if low rigidity material is used. Pooling issue may occur because screw's boss position for module's bracket are deformed open-close test. Solid structure design of system rear-cover may also influence the rigidity of system rear-cover. The deformation of system rear-cover should not caused interference.</p>

5	Assembly SOP examination for system front-cover with hook structure
Definition	<p>To prevent panel crack during system front-cover assembly process with hook structure, it is not recommended to press panel or any location that relate directly to the panel.</p>

6	Permanent deformation of system cover after reliability test
○	<ul style="list-style-type: none"> ● System front-cover ● System rear-cover
✗	<ul style="list-style-type: none"> ● System front-cover ● System rear-cover
○	<ul style="list-style-type: none"> ● System front-cover ● System rear-cover
✗	<ul style="list-style-type: none"> ● System front-cover ● System rear-cover
✗	<ul style="list-style-type: none"> ● System front-cover ● System rear-cover
✗	<ul style="list-style-type: none"> ● System front-cover ● System rear-cover
Definition	<p>System cover including front cover and rear cover may deform during reliability test. Permanent deformation of system front cover and rear cover after reliability test should not interfere with panel. Because it may cause issue such as pooling, abnormal display, white spot and also cell crack.</p> <p>Note: If the interference cannot be avoided, please feel free to contract INX FAE Engineer for collaboration design. We can help to verify and pass risk assessment for customer reference.</p>

7	Design gap A between panel & any components on system rear-cover
Definition	<p>System cover including front cover and rear cover may deform during reliability test. Permanent deformation of system front cover and rear cover after reliability test should not interfere with panel. Because it may cause issue such as pooling, abnormal display, white spot and also cell crack.</p> <p>Note: If the interference cannot be avoided, please feel free to contract INX FAE Engineer for collaboration design. We can help to verify and pass risk assessment for customer reference.</p>

8	Design gap B between system front-cover & panel surface
Definition	<p>Gap between system front-cover & panel surface is needed to prevent pooling or glass broken. Zero gap or interference such as burr and warpage from mold frame may cause pooling issue near system front-cover opening edge. This phenomenon is obvious during swing test, hinge test, knock test or during pooling inspection procedure.</p> <p>To remain sufficient gap, design with system rib higher than maximum panel thickness is recommended.</p> <p>Note: If the interference cannot be avoided, please feel free to contract INX FAE Engineer for collaboration design. We can help to verify and pass risk assessment for customer reference.</p>

9	Design gap C between panel & system front-cover or protrusions
Definition	<p>Gap between panel & system front-cover or protrusions is needed to prevent shock test failure. Because system front-cover or protrusions with small gap may hit panel during the test. Issue such as cell crack, abnormal display may occur.</p> <p>The gap should be large enough to absorb the maximum displacement during the test.</p> <p>Note: If the interference cannot be avoided, please feel free to contract INX FAE Engineer for collaboration design. We can help to verify and pass risk assessment for customer reference.</p>

10	Design distance between TP AA to LCD AA
Definition	TP VA should avoid TP ink area covering LCD AA or causing the module frame to be exposed.

11	Use OCR Lamination
Definition	<ol style="list-style-type: none"> 1. OCR glue as possible beyond module, in order to avoid Line Pooling 2. Add side glue to avoid Line Pooling